

LAMP® FD80-H HEAVY DUTY SLIDING DOOR SYSTEM Installation Manual (Ceiling Mount Type for Pocket Door, with Two-way Soft Close)

Part No.FD80DHCHP-PD

Thank you for selecting our product. Before starting installation, please read this manual thoroughly to ensure correct installation. Please keep this manual at hand for future reference.

ABOUT THE PRODUCT

- For residential & commercial use.
- Built in soft closer, enables two-way soft closing movement in both direction.
- Two sections of track for easy maintenance after installing.

SPECIFICATIONS

Door height	Max. 2500 mm	2501 – 2700 mm
Door width	784 – 1500 mm	850 – 1500 mm
Min. Door thickness	34 mm	
Max. Door weight	80 kg/door	
Height adjustable range	1 mm upward, 4 mm downward	

- The closing speed of the soft closing type door may change depending on the ambient temperature, operating method or installation quality.
- Recommended ambient temperature range is 5 to 40 °C .

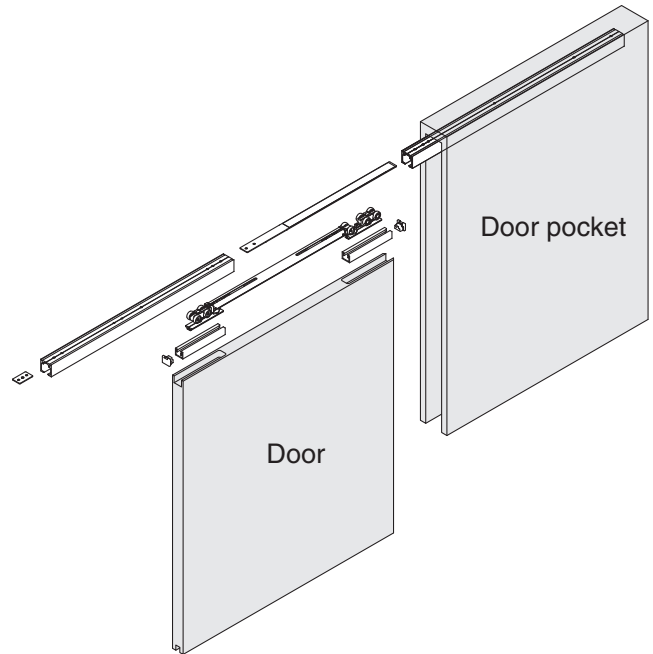

FOR YOUR SAFE WORK AND CORRECT INSTALLATION

Meaning of symbols

Warning Caution	Prohibited	Required
------------------------	-------------------	-----------------



Warning : If not followed, it may result in death or serious injury.



- This product should be installed by a qualified person. If the system is not installed correctly, the door will not operate smoothly, and may cause injury.
- It is necessary to manufacture the frame with sufficient strength so that it endures the weight of the door and any impact upon opening/closing the door. Only use designated screws and ensure that they are fastened firmly. A frame with poor strength or loose screws might result in the door falling and causing injury
- Do not use this product for any other purpose, or with doors that are outside the specifications of this manual.
- Do not disassemble or modify any parts other than those described in this document.

Caution : If not followed, it may result in injury or damage.

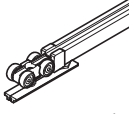
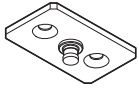
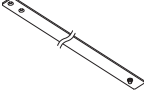
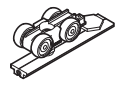
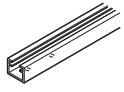
- Make sure to follow the designated dimensions, specifications, and horizontal/vertical angles. Make sure that the frame and door are not warped, since it may affect the movement of the door.
- If cutting any parts, make sure to remove any burrs before installation. Also check the upper track for any left-over burrs or scraps and remove these.
- This product is a part for architectural fittings. After installation, make sure to test the finished product thoroughly to ensure that it is functioning and safe. Please inform the end user how to use the product safely.
- Make sure to check the screws for slack at regular intervals (one month from first usage, half a year, and then one time every year is recommended).
- When installing the “pocket door” specification, make an “easy-maintenance” structure. For example, use a removable panel.
- We recommend that the installation is carried out by two people, in order to ensure proper installation and avoid unnecessary stress on the parts.

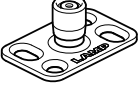
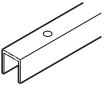
COMPONENT PARTS

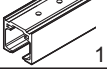
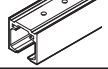
No.	①	②	③	④	⑤	⑥	⑦	⑧
Name	Recessed mount soft closer (two-way)	Front trigger	Pocket trigger	Recessed mount roller	Hanging bracket	End cap	Floor guide	Door guide track
Order code	250-022-239	250-029-709	250-025-460	250-022-241	250-120-608	250-121-142	250-029-718	250-019-971
Part No.	FD80-WRH-DSC	FD80-TRGPF	FD80-TRGPB-HB	FD80-WRH	FD70B-HB160	FD70B-EC-BL	FD50-BGR18	FD30-HBRT1500SIL
Parts	 1 pc	 1 pc	 1 pc	 1 pc	 2 pcs	Black  2 pcs	 1 pc	 1 pc
Accessories	Hex key 3 mm	Countersunk head tapping screws 4 x 40 2 pcs	Countersunk head tapping screws 4 x 40 2 pcs	Hex key 3 mm	Pan head tapping screws 5 x 40 4 pcs		Countersunk head tapping screw 4 x 20 4 pcs	Recommended screw : Countersunk head tapping screws 4 x 20

⑨	⑩	⑪
Open area track	Door pocket track	Spanner
Available with various length and finishes		250-022-252
FD80-TRP Series		FD80-HHSP
The profile of ⑨ and ⑩ are the same, but the cut length and hole location are different. See installation procedure 11 for the detail.		
 1 pc	 1 pc	 1 pc
Countersunk head tapping screws 5 x 40 (Q'ty depends on the hole location)		Nominal designation 13 mm, 22 mm

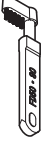
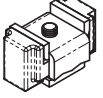
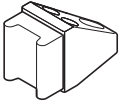
No.	⑫	⑬	⑭
Name	Cleaner for upper track	Stopper block	Door stopper (floor)
Part No.	FD50-TRC	FD80-HSB	FD80-HTK
Parts			

✗ FD80 Below parts which are packed with recessed mount soft closer ① are not needed for this application.

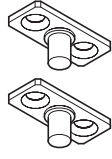
Trigger : 2 pcs

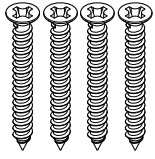

Countersunk head tapping screws 4 x 30 D6 : 4 pcs

TOOLS REQUIRED FOR INSTALLATION

- Philips head driver #2
- Machine or tool for cutting aluminum alloy
- Drill bit for metal: $\phi 5$
- Drill bit for metal (for $\phi 11.4$ countersunk hole)

INSTALLATION DRAWING (EXAMPLE)

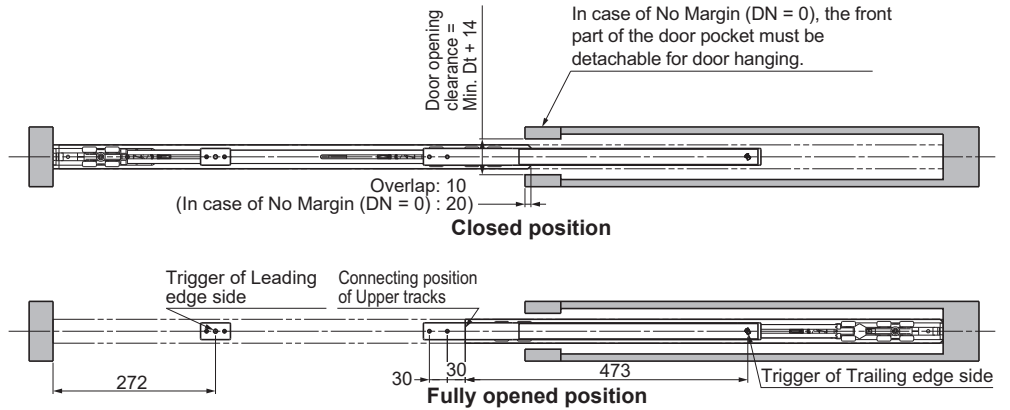
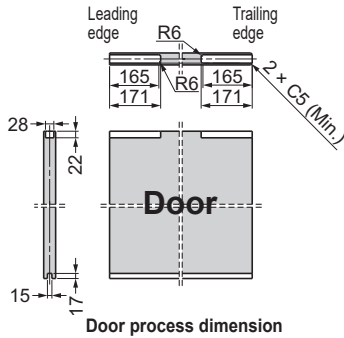
The example shows the sliding door when the leading edge (at the fully opened position) is aligned with the connecting position of the upper tracks. To shift the connecting position towards the trailing edge, see page 11.



[Recommended]
Door pocket track length (Lp) = Door width (DW)
(The end of door pocket stops the door.)

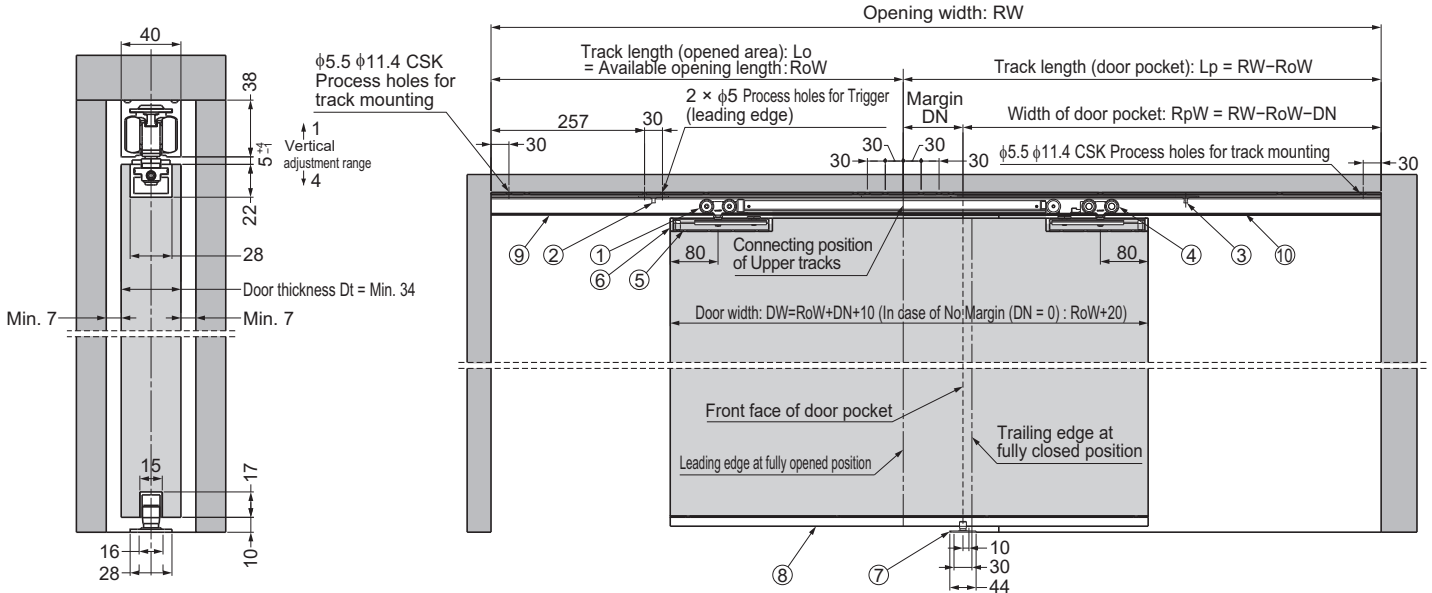

When the door pocket track is longer than the door width. (Lp > DW)
(Door stoppers are needed to stop the door.)

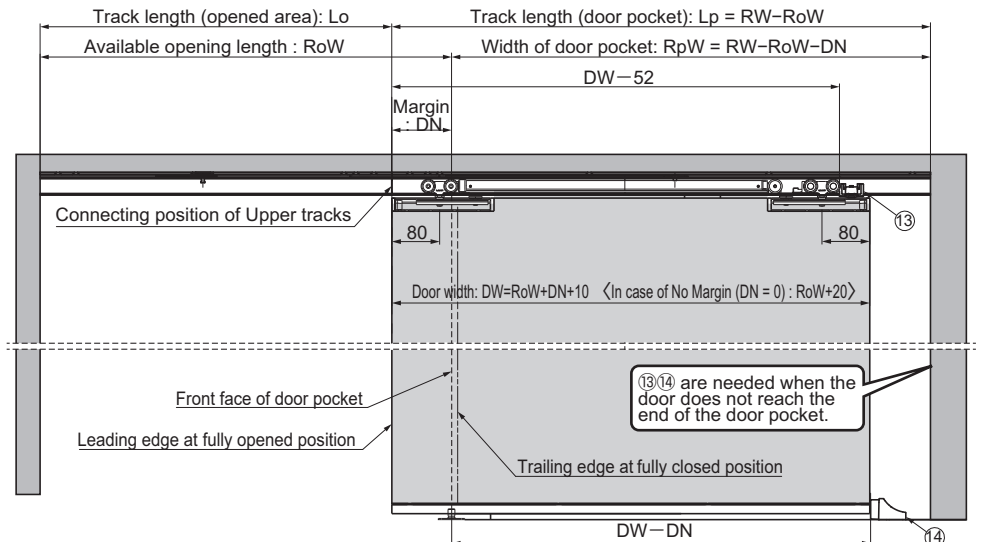

INSTALLATION PROCEDURE

1 Cutting Track and Hole Drilling on Upper Track

⚠ Caution

❗ When cutting, reinforce the track to prevent deformation at the cut section.

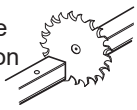

⚠ Caution

⊘ Do not cut the track on the side with three holes.

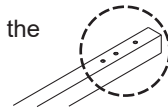

When using 1260 mm track

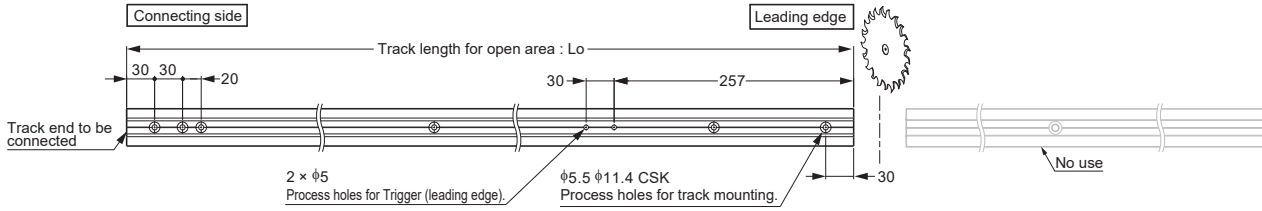

Open area track

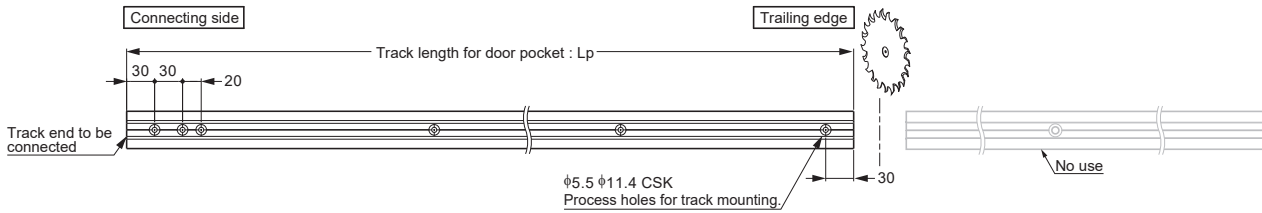

Door pocket track

When cutting from a long track (2160 mm, 2760 mm, 3960 mm)

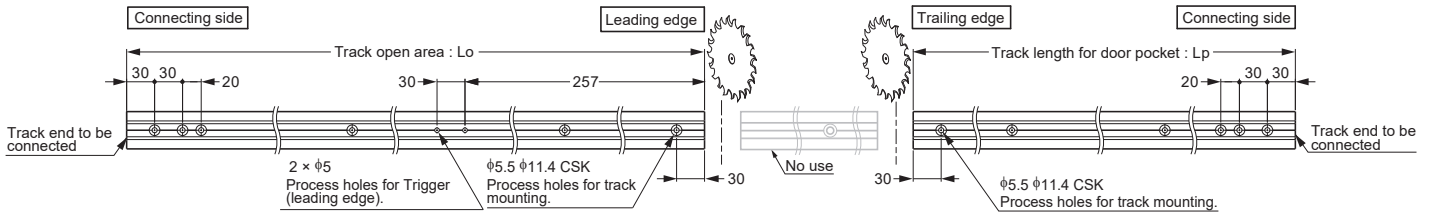

Open area track

Door pocket Track

2 Installing Door Pocket Track

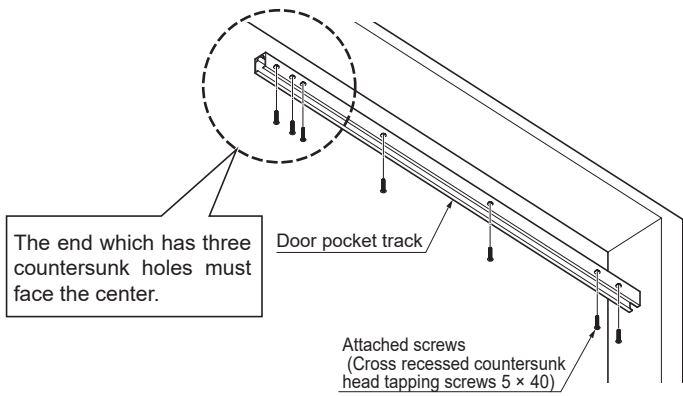

Caution
Remove any dirt or aluminum chips from the track



When the door pocket track is longer than the door width. ($L_p > DW$)

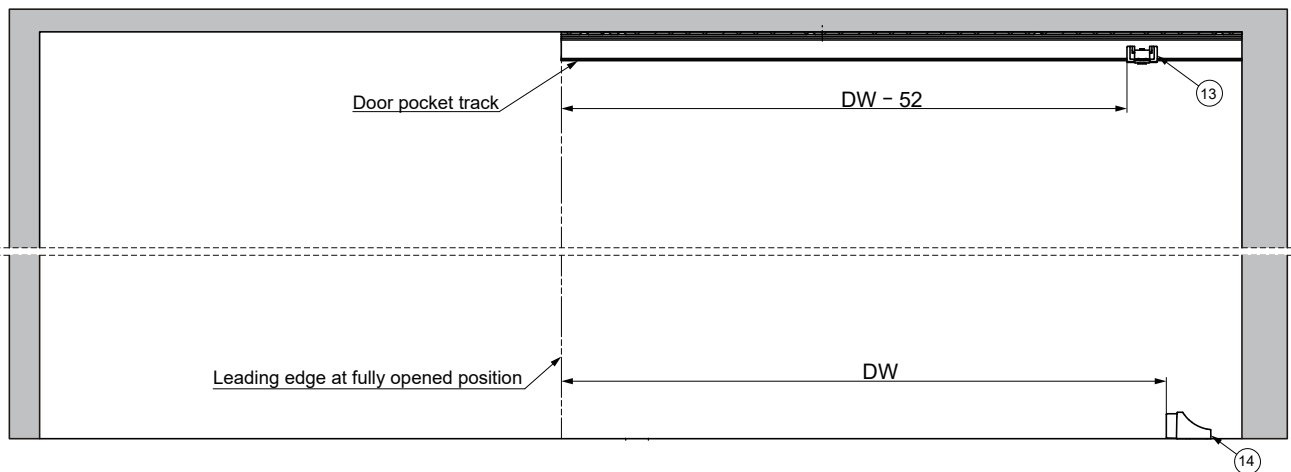
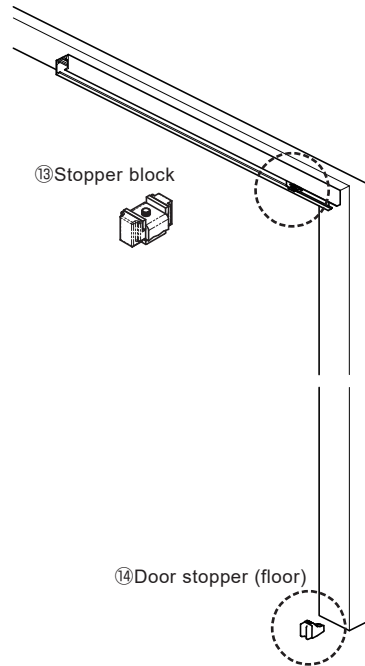

3 Installing Hanging Bracket

Fixing position

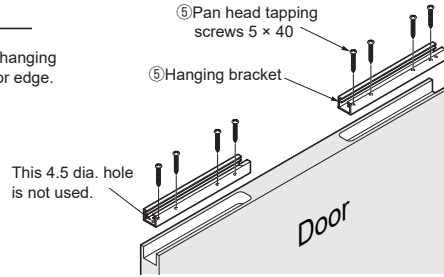
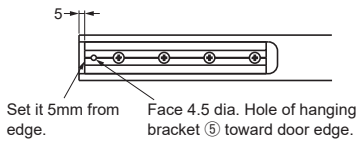

4 Installation of Guide Track

(1) Cut the track to the same length as the door width.

! Caution

! When cutting, reinforce the track to prevent deformation at the cut section.

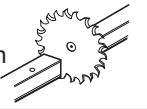

(2) Fasten the track with countersunk head tapping screw 4x20 (not provided).

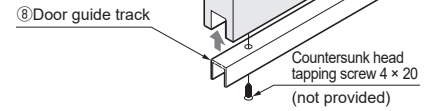

5 Installing Pocket Trigger

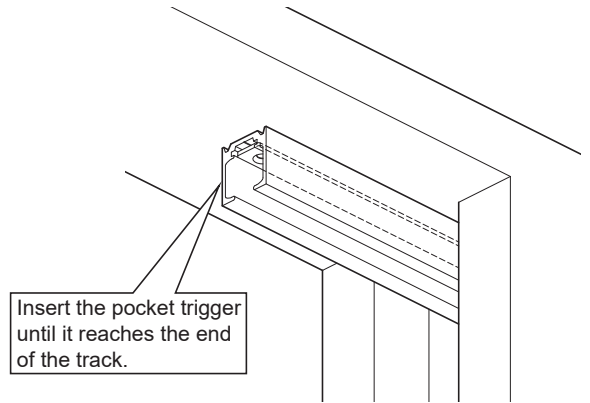
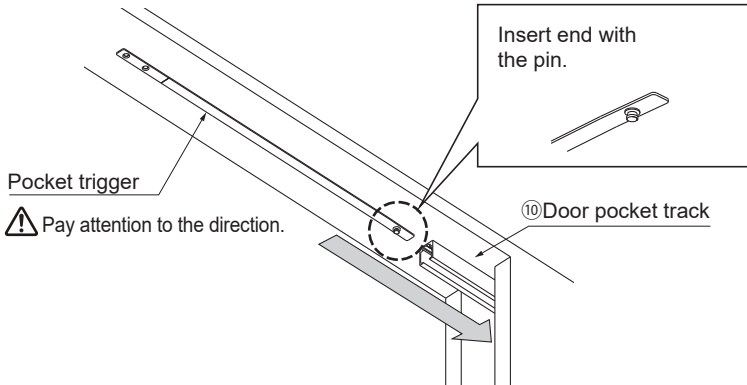

6 Verification Before Installing the Soft Closer

! Caution

! Without verification the self closing feature may fail.

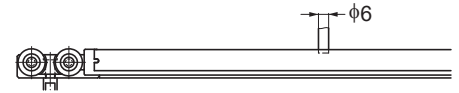
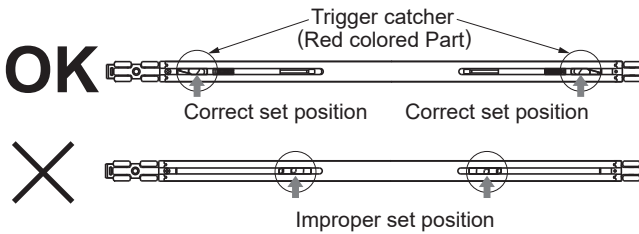

If the trigger position is wrong, pull back the trigger catcher to the correct position using a 6 mm diameter round bar.

7 Inserting Parts into Open Area Track.

Insert the parts in order from ① to ③ with care of direction. You can insert the parts smoothly from the connecting end which has no burrs.

! Caution

! Remove any dirt or aluminum chips from the track.

! Caution

! Tape around rollers and upper track to prevent inserted parts from falling.

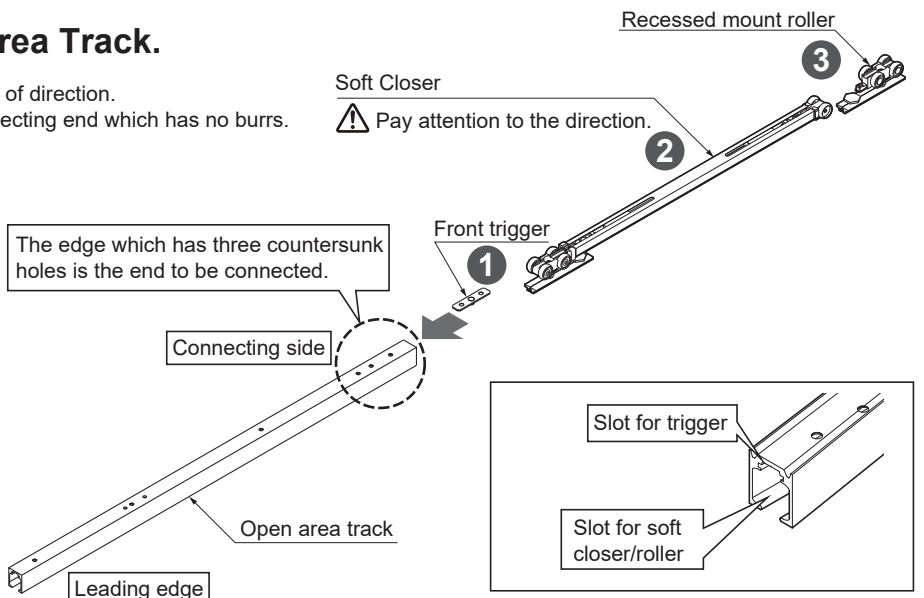
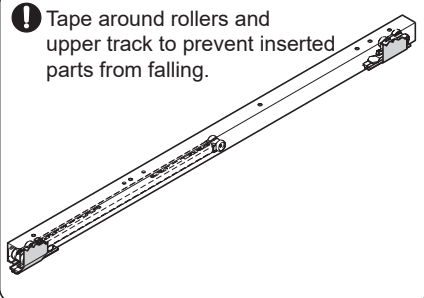

8 Mounting Open Area Track.

[1] Connecting to door pocket track.

Align the track end to the end of the door pocket track.

Pull out the pocket trigger from the door pocket track, and insert it into the open area track.

⚠ Caution

- ❗ Remove any dirt or aluminum chips from the track.

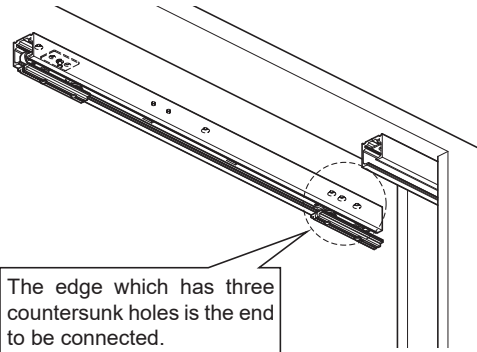

⚠ Caution

- ❗ Overlap the two countersunk holes on the pocket trigger and the two holes on the open area track. Deviation of the joint position makes insertion of the trigger difficult.

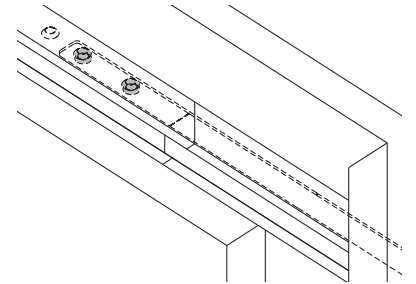

⚠ Caution

- ⚠ When sliding the pocket trigger, use a screwdriver. The screwdriver may unexpectedly come out and damage the track.

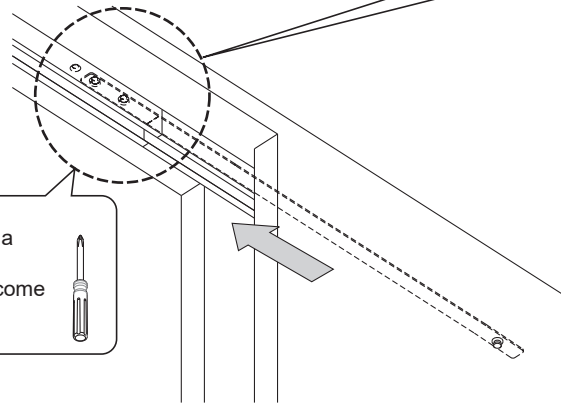

[2] Fastening trigger and track

Fasten the open area track and pocket trigger with provided screws in order of ① to ⑤. Move rollers if they cover the fastening holes on the track.

⚠ Caution

- ⚠ When tightening the ① screws make sure that the both tracks are aligned.

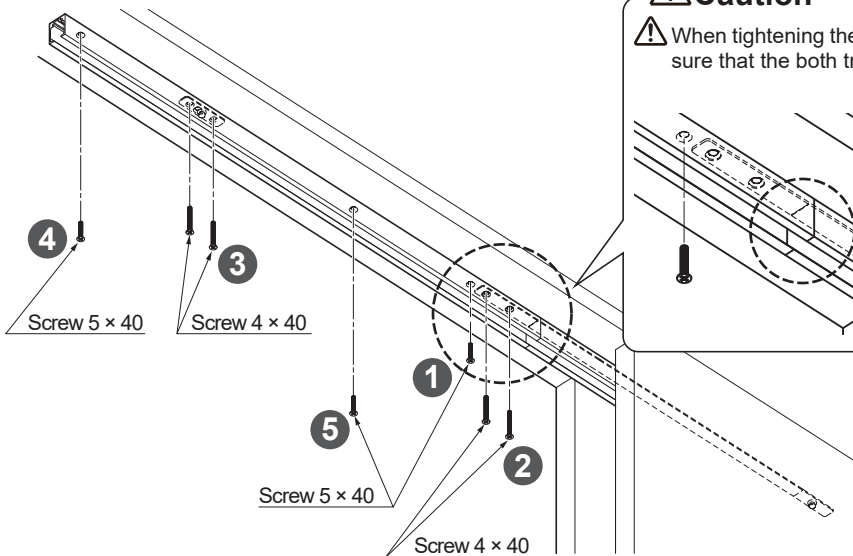

⚠ Caution

- ❗ Be careful not to misalign the tracks. Tighten the screws firmly.

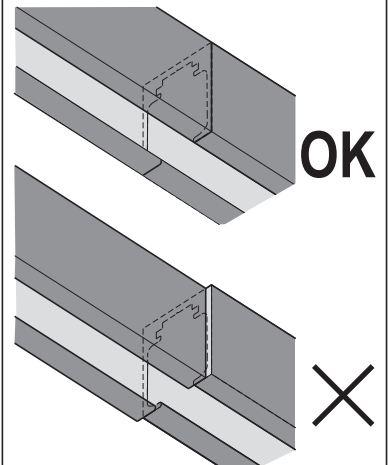

⚠ Caution

- ❗ After fixing the track, move rollers and check if there's any misalignment or gap between the tracks.

9 Mounting Floor Guide Temporarily

Position floor guide just below the center of upper track.

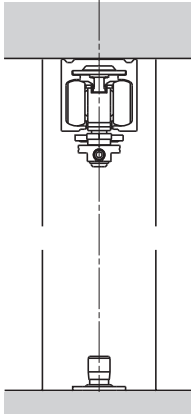

Caution
 The position of the model where the margin occurs is shown in the figure.

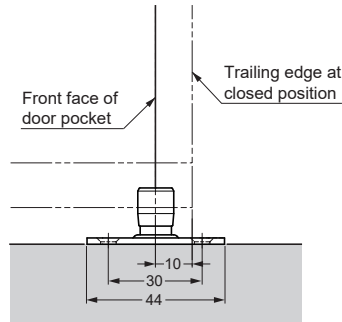

Temporarily fasten through the slotted holes with the provided screws.

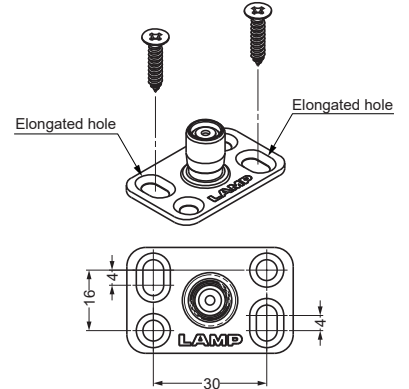

10 Hanging Door

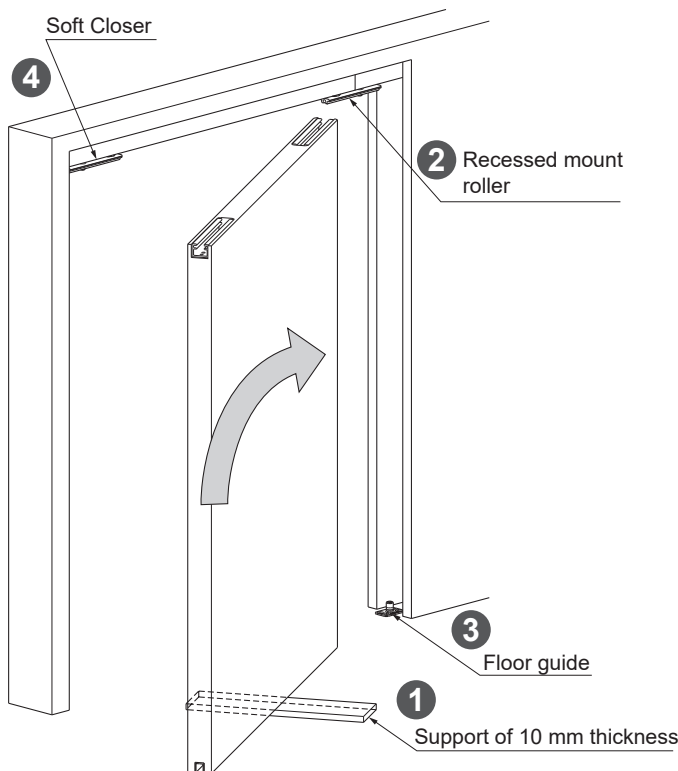

Insert the roller into the hanging bracket in the door. Position roller hanger bolt to 80mm from door edge (41 mm to fix plate edge). Tighten fix bolt with Spanner ⑪.

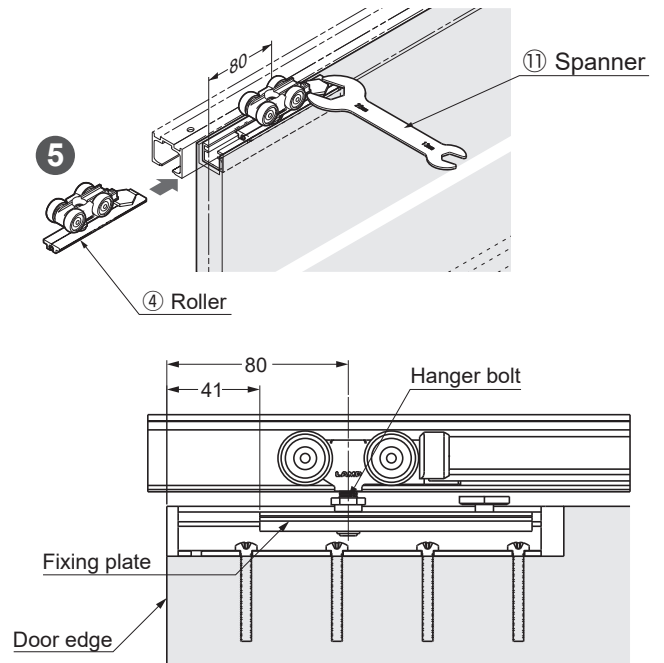

11 Verification of Soft Closer Operation

- (1) Remove the 10 mm support from under the door.
- (2) Close the door slowly and check that the soft closer works correctly. The soft closer is engaged approximately 115 mm at the leading edge before the door reaches its final position.
- (3) Carry out similar verification for the door trailing edge.
- (4) Please refer to the "Troubleshooting" section when the soft closer does not work correctly.

Caution

Do not close the door with excessive force. It may cause damage to the soft close mechanism.

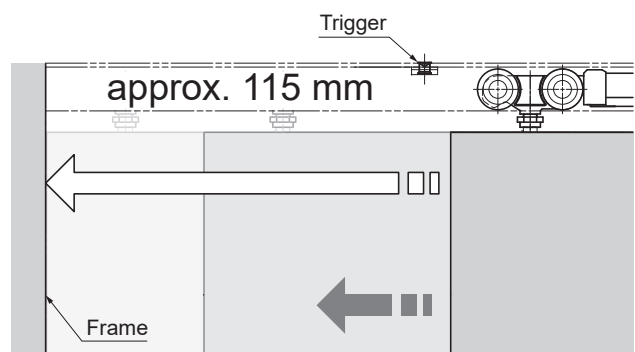

12 Adjusting The Door Position

Adjust the door so that it is parallel to the upper track with 6-11 mm of clearance between the door and floor.

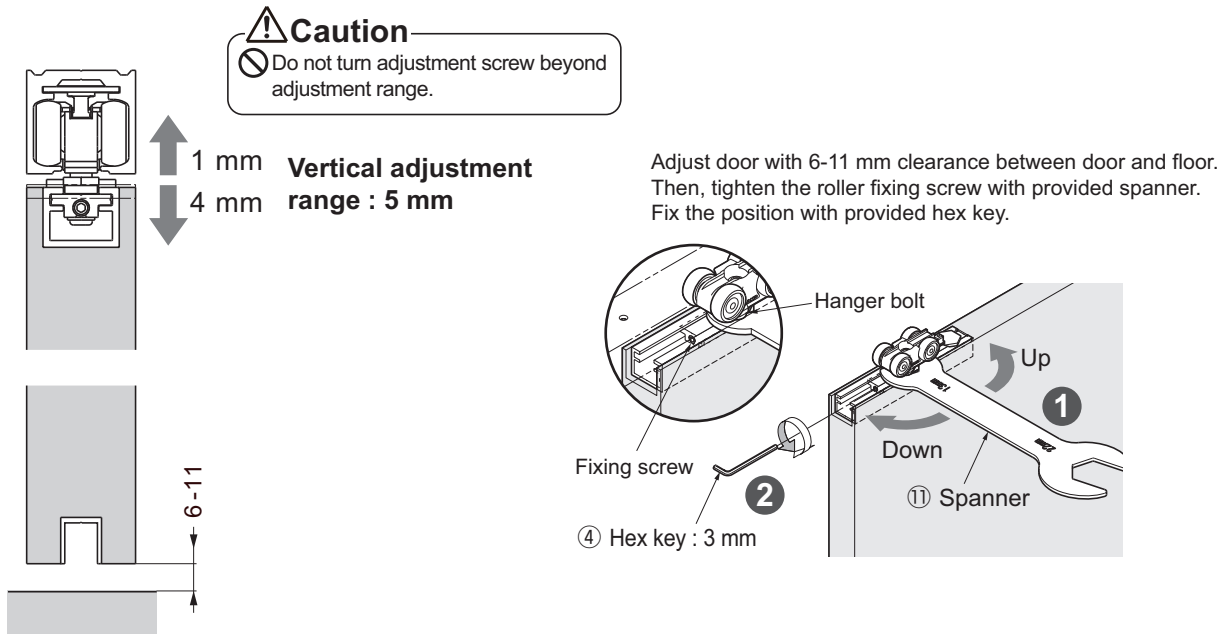

Insert end cap into hanging bracket.

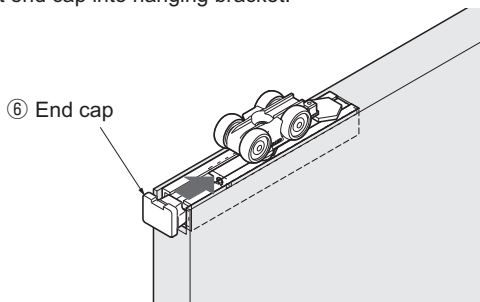

13 Adjusting, Fixing Floor Guide

If the door movement is not smooth, remove the door, then adjust the floor guide forwards or backwards.

Tighten all 4 screws after the adjustment.

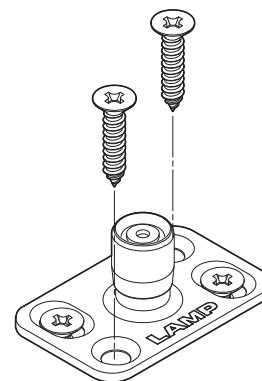
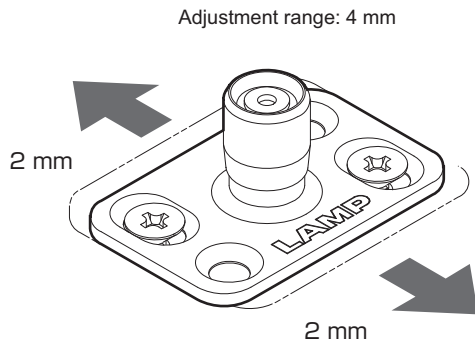

Appendix 1 How to Remove the Door, Track

[1] How to remove the door

- ① Put a support of 10 mm thickness under the door.
- ② Remove the end cap.
- ③ Loosen fixing bolt with spanner ⑪.
- ④ Pull out roller.
- ⑤ Pull out the door, while making sure not to let it scratch against the door pocket.
- ⑥ Pull out the roller on the trailing edge.

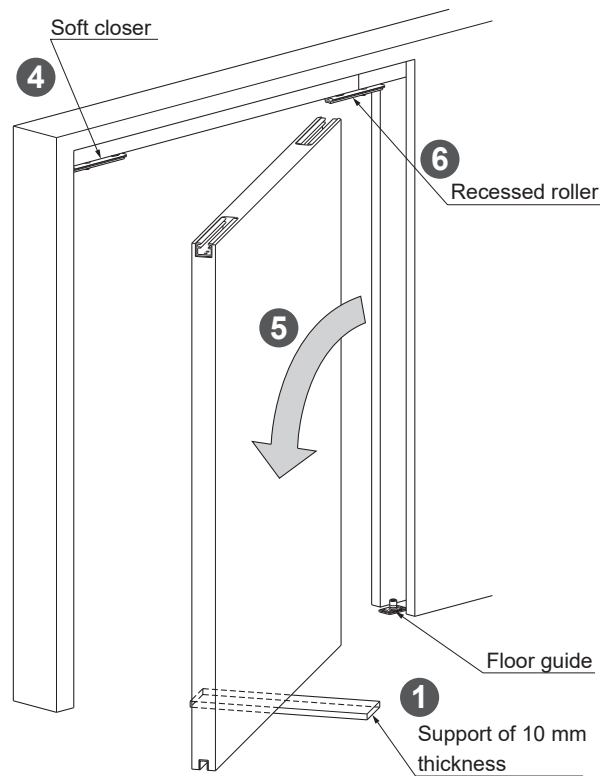
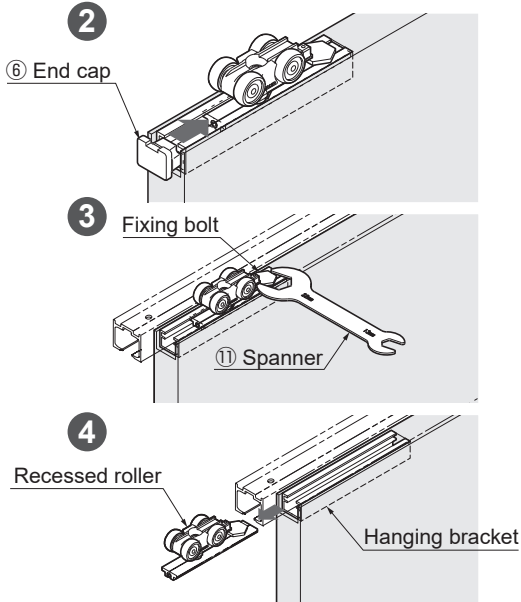

[2] How to remove upper track

- ① Remove the pocket trigger screws.
- ② Slide the pocket trigger into the door pocket track.
- ③ Remove the open area track.

⚠ Caution

⚠ The trigger can be deformed if the open area track is removed before the pocket trigger being moved into the pocket track.

Hold the open area track when removing the last screw.

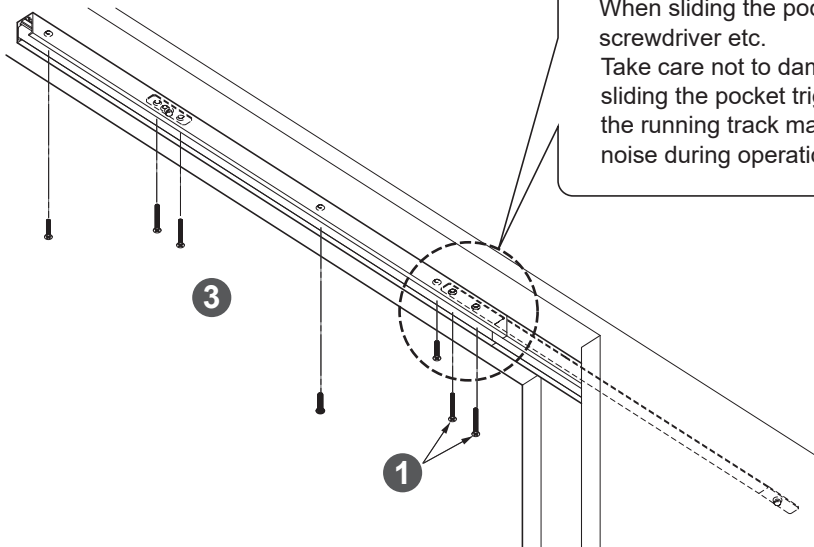

⚠ Caution

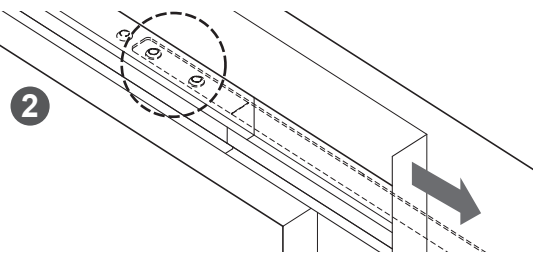

When sliding the pocket trigger, use a screwdriver etc. Take care not to damage the track when sliding the pocket trigger. Scratches on the running track may cause a roller noise during operation.

Appendix 2 How to Shift The Connecting Position of the Tracks

[1] When determining the trigger position on site

- (1) Put a mark on the open area track with reference to the front end of the door at the fully opened position. (Use masking tape so that the track isn't marked.)
- (2) Drill additional holes for pocket trigger. Remove the door according to the procedure - **Appendix 1**: How to remove the door, then remove the open area track.
 - Drill additional holes for trigger on the open area track. (See the drawing below.)

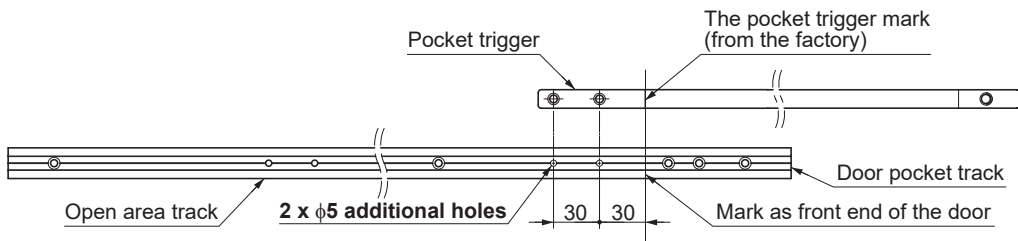
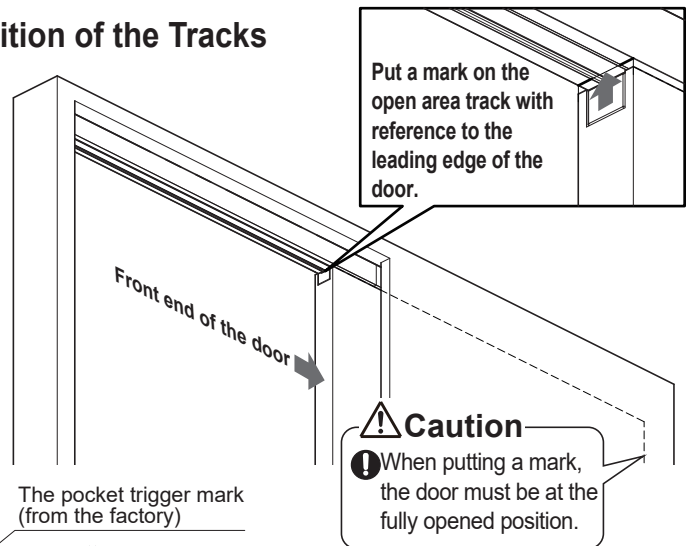

- (3) Mounting open area track
Follow the right figure, since the working sequence is different from the regular process.
- (4) Hanging the door
Refer to the procedure 「**2**」 and the following procedures on page 3.

Working sequence for mounting the open area track (common to [1] and [2])

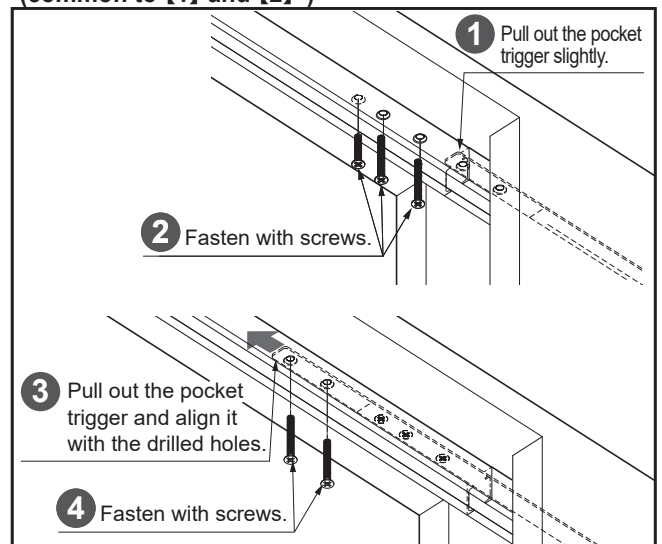

[2] How to process the holes for Pocket trigger in advance

[Example] Door pocket track with length equal to the width of the door pocket.

- (1) Drill holes for the pocket trigger according to the drawing below.
- (2) Fix the open area track, while following the above right figure, since the working sequence is different from the regular process.

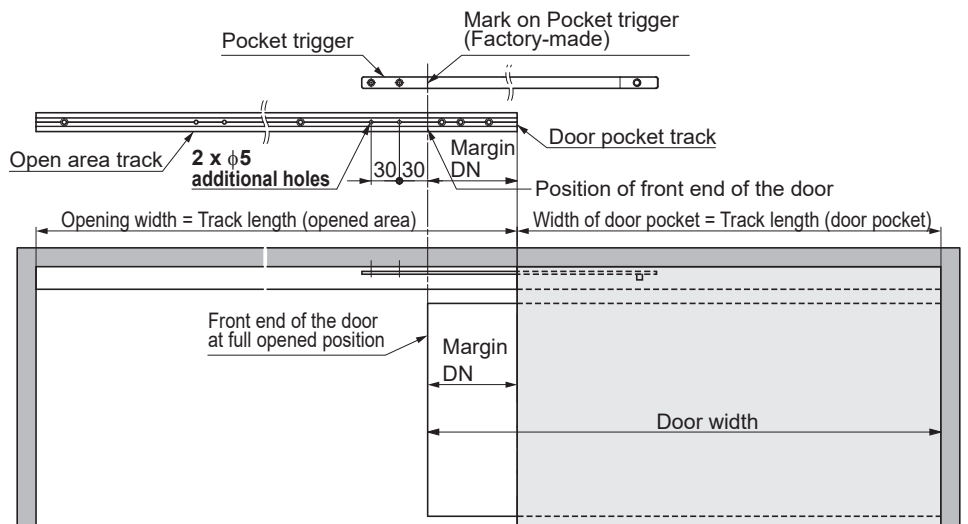

Final verification Verify that all screws are securely tightened, and verify that all screws have been used.

PERIODICAL INSPECTION

- Clean the inside of the track.
- Check the upper and lower space of the door. If necessary, correct the space.

■ TROUBLESHOOTING

Trouble	Checkpoint	Solution
Door stops during soft closing	Check if door bottom contacts the floor or floor guide.	Verify that the track mounting screws are not loosened. Then, adjust the door height such that the clearance between the door bottom and floor is 6 - 14 mm.
	Check if the upper track is set horizontally.	Using a level gauge, reset the upper track horizontally.
	Check if mohair seal is installed.	Reduce the friction between the mohair seal and door.
No soft closing	Check if trigger is installed.	Install trigger to specified position.
	Check if door is closed by excessive force.	Do not close door by excessive force as it may damage the soft closer.
	The position of the trigger catcher in page 6 section 6 may become dislocated. (It is hidden as installed in upper track.)	Remove the door and the upper track, then check the status of the trigger catcher in section 6 .
Abnormal noise during operation	Check if door bottom contacts the floor or floor guide.	Verify that the track mounting screws are not loosened. Then, adjust the door height such that the clearance between the door bottom and floor is 6 - 14 mm.
	Check if door touches adjacent parts.	Adjust position of the floor guide.
	Check track rollers for aluminum dust.	Remove the track, then pull out and clean the roller.
	Check the track mounting screws for looseness.	Retighten the screws to free the roller.
Heavy door operation	Check if door bottom contacts the floor or floor guide.	Verify that the track mounting screws are not loosened. Then, adjust the door height such that the clearance between the door bottom and floor is 6 - 14 mm.
	Check if door touches adjacent parts.	Adjust position of the floor guide.
Door does not move.	Check the track retaining screws for looseness.	Retighten the screws to free the roller.
Door starts to move.	Check if the upper track is set horizontally.	Using a level gauge, reset the upper track horizontally.
Door stops or is caught during operation.	Check if there is any gap or misalignment between the tracks.	Correct the misalignment or gap.

SUGATSUNE KOGYO CO.,LTD
 Tokyo, JAPAN

Phone: +81 (0)3 3866 2260 E-mail:export@sugatsune.co.jp

SUGATSUNE KOGYO (UK) LTD
 Reading, UK

Phone: +44 118 9272 955 E-mail:sales@sugatsune.co.uk

SUGATSUNE EUROPE GmbH
 Düsseldorf, GERMANY

Phone: +49 211 53812900 E-mail:sales@sugatsune.eu

SUGATSUNE SHANGHAI Co., LTD
 Shanghai, CHINA

Phone: +86 21 3632 1858 E-mail:lamp@sugatsune.com.cn

Guangzhou, CHINA

Phone: +86 20 6639 3552 E-mail:lamp@sugatsune.com.cn

SUGATSUNE KOGYO INDIA PRIVATE LIMITED
 Mumbai, INDIA

Phone: +91 22 28314490/91 E-mail:sales@sugatsune.in

SUGATSUNE AMERICA, INC
 California, USA

Phone: +1 310 329 6373 E-mail:sales@sugatsune.com

Chicago, USA

Phone: +1 312 461 1081 E-mail:chicagoshowroom@sugatsune.com.

SUGATSUNE CANADA, INC.

Phone: +1 514 312 5267 E-mail:support@sugatsune.ca

ISO9001(Japan Offices and Sugatsune America) and ISO14001(Chiba Production division and Logistics center), certified.

2020.02 1047-4