

TORQUE DAMPER INTRODUCTION

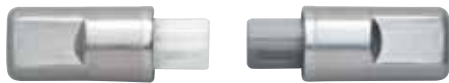

UDH-14

- Keeps lid from slamming shut.
- Hinge torque within compact cartridge.
- Operating temperature: 32°F~104°F (0°C~40°C)

UDH-16



UDH



UDH-16N

Item No.	Torque per piece (lbs-in)	Torque per piece (kgf-cm)	Page	10	20	30	40 (kgf-cm)
UDH-14A (B) LS	4.4~7.1	5.1~8.2	254	[Bar chart showing torque ranges]			
UDH-14A (B) MS	7.1~13.3	8.2~15.3					
UDH-14A (B) HS	13.3~22.1	15.3~25.5					
UDH-16A (B) MS	8.8~15.0	10.2~17.3	255	[Bar chart showing torque ranges]			
UDH-16A (B) HS	15.0~22.0	17.3~25.5					
UDH-16NA (B) MS	15.0~21.2	17.3~24.5					
UDH-16NA (B) HS	19.4~26.6	22.4~30.6					
UDH-A (B) MS	13.0~21.0	15.3~25.5					
UDH-A (B) HS	21.0~30.0	25.5~35.7					
UDH-AGS	30.0~34.0	35.0~40.0					

TORQUE DAMPER



UDH-14



- Keeps lid from slamming shut.
- High torque within compact cartridge.
- Operating temperature: 32°F~104°F (0°C~40°C)

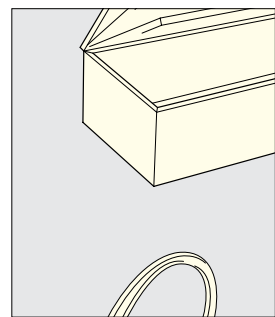
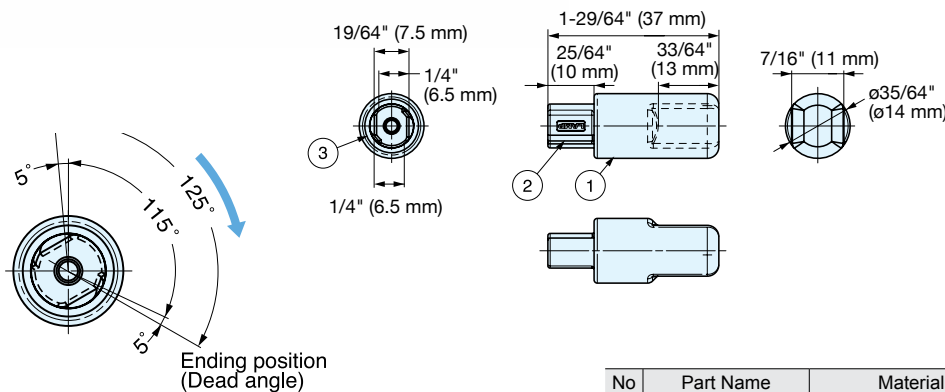

Application

No	Part Name	Material	Finish
①	Body	304 Stainless Steel	Plain
②	Shaft	PBT Plastic	A-White, B-Grey
③	Cover Ring		-

* NSF Component

1-29/64" (37 mm)

Item No.	Torque per piece	Dampening Direction	Weight (g)	Box (pcs)	Carton (pcs)
UDH-14ALS	4.4~7.1 lbs-in (5.1~8.2 kgf-cm)	Counter Clockwise	10	40	400
UDH-14BLS		Clockwise			
UDH-14AMS*	7.1~13.3 lbs-in (8.2~15.3 kgf-cm)	Counter Clockwise			
UDH-14BMS		Clockwise			
UDH-14AHS*	13.3~22 lbs-in (15.3~25.5 kgf-cm)	Counter Clockwise			
UDH-14BHS*		Clockwise			