

LEVELING GLIDE

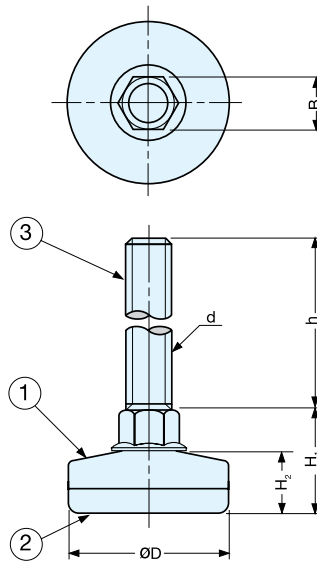

LOAD CAPACITY
140 kg
308 lbs

TN



No.	Part Name	Material	Finish
①	Body	Steel	Chrome
②	Base	Polypropylene	Natural
③	Bolt	Steel	Clear Zinc Chromate

Item No.	D	H ₁	H ₂	h	d	B	Load Capacity	Weight (g)	Box (pcs)	Carton (pcs)
TN-25S	31/32" (25 mm)	27/32" (21 mm)	15/32" (12 mm)	2-3/8" (60 mm)	M10x1.5	1/2" (13 mm)	308 lbs (140 kg)	50	50	500
TN-35S	1-3/8" (35 mm)	7/8" (22.5 mm)	17/32" (13.5 mm)					60	30	300
TN-45S	1-23/32" (43.5 mm)		70					20	260	

LEVELING GLIDE (PARTS SEPARABLE)



LOAD CAPACITY
50-270 kg
110-594 lbs

EA

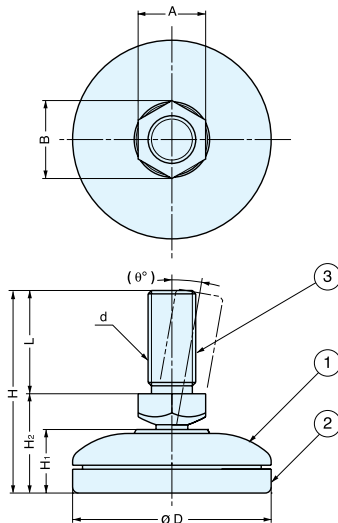

- Bolt swivels to compensate for uneven floors.
- Parts can be easily separated for recycling purpose.

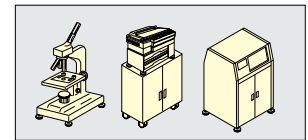
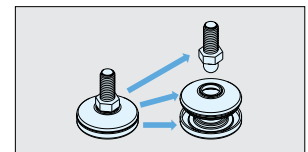

Installation

No.	Part Name	Material	Finish
①	Body	ABS	Dark Grey
②	Base		
③	Bolt	Steel	Chromate

Item No.	A	B	D	H	H ₁	H ₂	L	θ°	d	Load Capacity	Weight (g)	Box (pcs)	Carton (pcs)
EA-25M6	5/16" (8 mm)	3/8" (9.2)	31/32" (25)	1-7/32" (31)	11/32" (8.5)	9/16" (14)	21/32" (17)	3/8" (10)	M6x1.0	110 lbs (50 kg)	10	120	1200
EA-30M8	3/8" (10 mm)	7/16" (11.5)	1-3/16" (30)	1-15/32" (37.5)	13/32" (10.5)	21/32" (17)	13/16" (20.5)	19/32" (15)	M8x1.25	220 lbs (100 kg)	20	80	800
EA-40M10	1/2" (13 mm)	19/32" (15)	1-9/16" (40)	1-21/32" (42.5)	1/2" (13)	13/16" (20.5)	7/8" (22)	1/2" (12.5)	M10x1.5	286 lbs (130 kg)	32	40	400
EA-50M12	21/32" (17 mm)	25/32" (19.6)	1-31/32" (50)	2" (51)	5/8" (16)	31/32" (25)	1-1/32" (26)	3/8" (10)	M12x1.75	594 lbs (270 kg)	60	20	200

() units in mm