

DRAW LATCH

PS/P

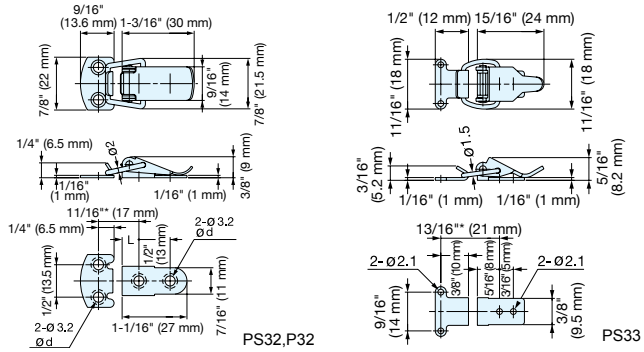

*Dimensions shown are for clamping force of "0".

Item No.	L	ød	Load Capacity	Weight (g)	Material	Finish
PS32	5/16" (7.5 mm)	3/16" (5.2 mm)	17.6 lbs (8 kg)	11	PS: 304 Stainless Steel	Polished
P32		5/16" (4.2 mm)		12		
PS33	-	-	11.0 lbs (5 kg)	6	P: Steel	Clear Zinc

DRAW LATCH

STAINLESS
304
STEEL

PS35

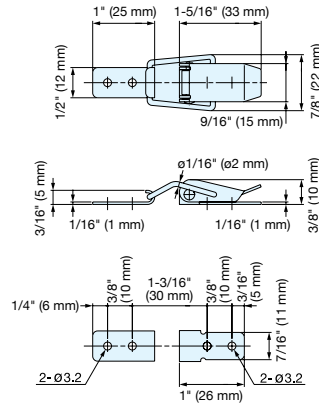

*Dimensions shown are for clamping force of "0.5".

Item No.	Load Capacity	Weight (g)	Material	Finish
PS35	4.4 lbs (2 kg)	15	304 Stainless Steel	Polished

DRAW LATCH

STAINLESS
304
STEEL

SCC25

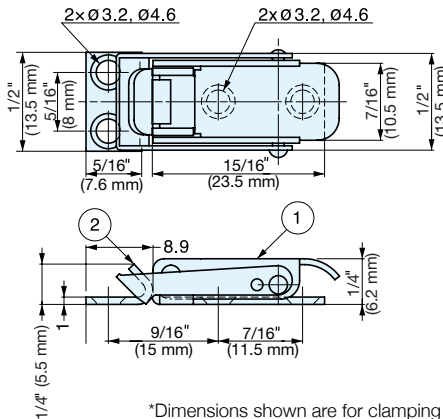

*Dimensions shown are for clamping force of "0".

Item No.	Weight (g)	Box (pcs)	Carton (pcs)	No.	Part Name	Material	Finish
SCC25	6	100	1000	①	Body	304 Stainless Steel	Polished
				②	Counterplate		