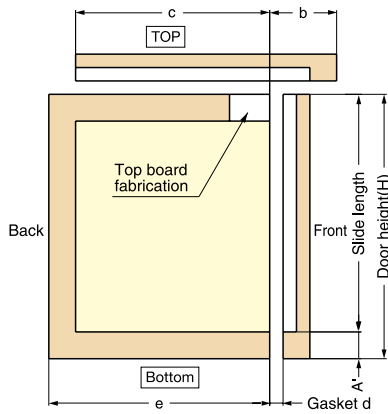
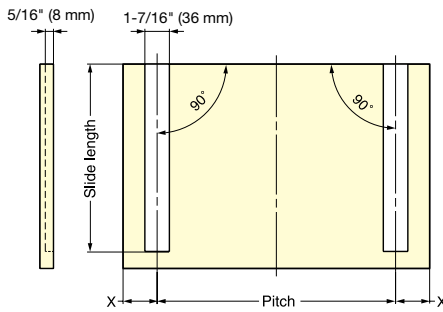
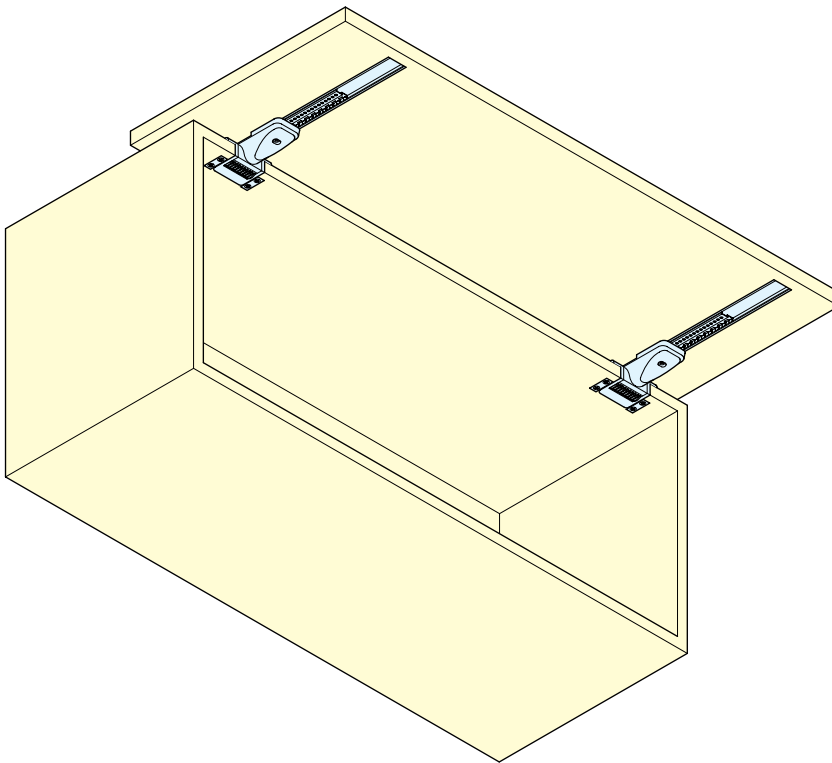
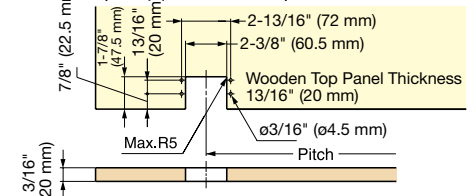
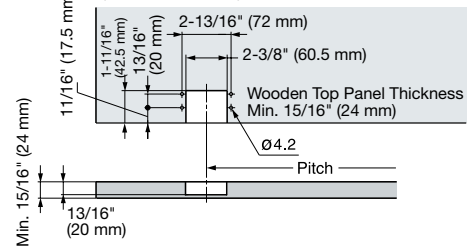

SOFT CLOSING MECHANISM

■ Cabinet Preparation
Cabinet Dimensions

Door Fabrication

	b	c	d	e		X
Wooden Top Panel	A'+81.4	H-b	2.5	Min. c+7	Inset Application	80
Metal Top Panel	A'+86.4	H-b	7.5	Min. c+7	Overlay Application	Side Board Thickness+80

Top Panel Fabrication
(Wooden Panel)

(Sheet Metal)

■ Installation
