

# RECESSED HOOK (W/SOFT CLOSE)



## NF-45D

HOOKS



NF-45D-GR    NF-45D-BL    NF-45D-SSL    NF-45D-WT

- A modern, clean hook solution with Motion Design Technology.
- Hook is spring loaded to retract and soft close.
- Ideal for vibration or shock applications.
- Panel Thickness: - Wood: Min. 1-1/16"~1-1/4" (27~31 mm)  
- Sheet metal: 1/32~3/16 (0.8~4.0 mm)
- Hook bracket (NF-45DB) for sheet metal sold separately.

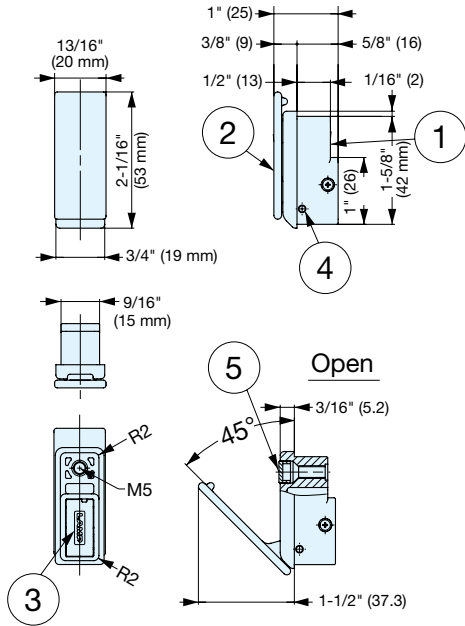

Wood panel (27~31mm)

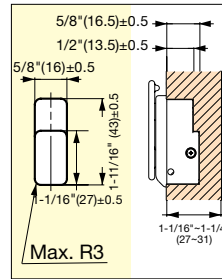

Wood panel (32mm or thicker)

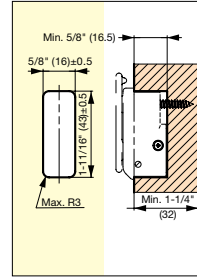

Sheet metal

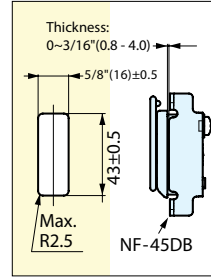

Cut Out Dimensions

No.	Part Name	Material	Finish
①	Body	Aluminum Alloy	Grey/Black/Silver White
②	Arm		
③	Cover	Polycetal	Plain
④	Pin	304 Stainless Steel	
-	Spring	Rubber	Black/White
⑤	Bumper		

Item No.	Color	Load Capacity of Arm	Load Capacity of Base	Weight (g)	Box (pcs)	Carton (pcs)
NF-45D-GR	Grey	21 lbsf (9.5 kgf)	112 lbsf (51kgf)	32	10	200
NF-45D-BL	Black					
NF-45D-SSL	Silver					
NF-45D-WT	White					

# RECESSED HOOK BRACKET



## NF-45DB



NF-45DB

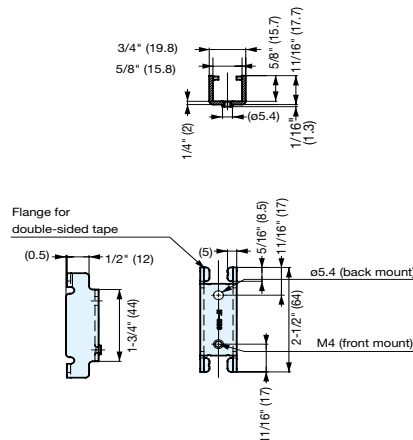

- Allows for the NF-45D hook to be mounted onto sheet metal.
- Can be mounted from both front and back sides.
- Has flanges for double-sided tape, which allows for temporary fixing before mounting.

Item No.	Material	Finish	Box (pcs)	Carton (pcs)
NF-45DB	Steel	Yellow Zinc Chromate	40	40

RECESSED HOOKS