

DUAL BRAKE SYSTEM CASTER (PLATE TYPE)



MX-125PS, P

- Caster with clean appearance.
- Dual brake system.
Can be locked on "swivel only" or "wheel and swivel" in one step. Large lock lever for swivel, and small lock lever for wheel.
- Easy operation.
- Works as rigid type when swivel locked for easy movability.



w/Brake

w/o Brake

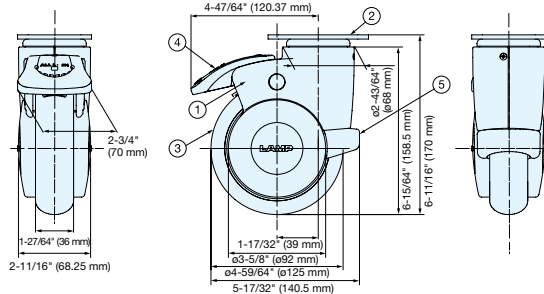
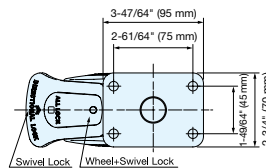

Item No.	Type	Load Capacity	Weight (g)	Box (pcs)	Carton (pcs)
MX-125PS	w/ Brake	264 lbs (120 kg)	1450	2	8
MX-125P	w/o Brake		1350		

No.	Part Name	Material	Finish
①	Body	Polypropylene	Light Grey
②	Mounting Plate	Steel	Chromate
③	Wheel	Nylon/Polyurethane	Dark Grey
④	Brake	Nylon	Blue
⑤	Rear Bumper	Polyurethane	Dark Grey

DUAL BRAKE SYSTEM CASTER (THREADED BOLT TYPE)



MX-125N

- Caster with clean appearance.
- Dual brake system.
Can be locked on "swivel only" or "wheel and swivel" in one step. Large lock lever for swivel, and small lock lever for wheel.
- Easy operation.
- Works as rigid type when swivel locked for easy movability.



w/Brake

w/o Brake

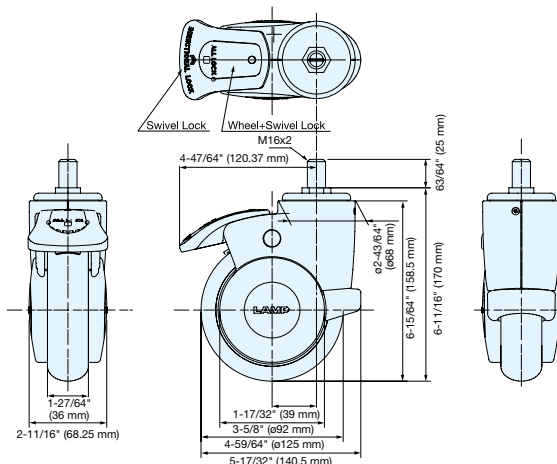

Item No.	d	Load Capacity	Weight (g)	Box (pcs)	Carton (pcs)
MX-125N16S	w/ Brake	264 lbs (120 kg)	1310	2	8
MX-125N16	w/o Brake		1210		

No.	Part Name	Material	Finish
①	Body	Polypropylene	Light Grey
②	Threaded Bolt	Steel	Chromate
③	Wheel	Nylon/Polyurethane	Dark Grey
④	Brake	Nylon	Blue
⑤	Rear Bumper	Polyurethane	Dark Grey