

# MINI GUIDE BLOCK

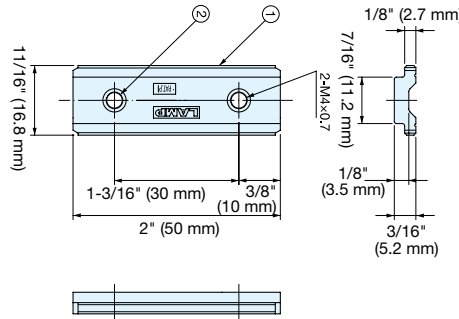

## MR-20CS



- Polyethylene resin with excellent sliding properties eliminates the need for grease or oil.
- Polyethylene resin has a high chemical resistance.
- UL94 HB grade flame resistance.

Item No.	Weight (g)	Box (pcs)	Carton(pcs)
MR-20CS	7	50	1000

No.	Material	Finish
①	Polyethylene (UL 94HB)	Grey
②	304 Stainless Steel	Plain

# MINI GUIDE BLOCK (PRELOAD TYPE)



## MR-20CNB

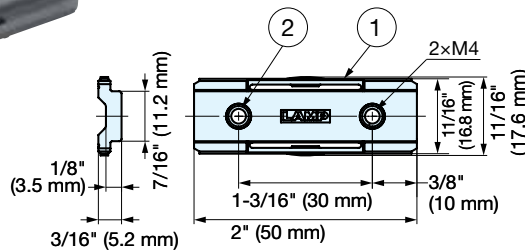

- Preload type minimizes rattling, maintains accuracy.
- Polyethylene resin with excellent sliding properties eliminates the need for grease or oil.
- Polyethylene resin has a high chemical resistance.
- UL94 HB grade flame resistance.

Item No.	Weight (g)
MR-20CNB	5

No.	Material	Finish
①	High Sliding Grade Polyethylene	Grey
②	304 Stainless Steel	Plain

# MINI GUIDE CLAMP



## MR-20CLP

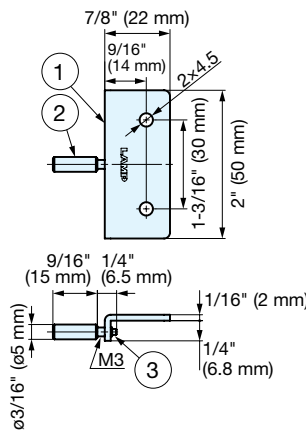

- Clamp used for temporary holding and positioning for mini guide rail MRS.
- Easy to fix in place by simply pushing on the sides of the rail.
- Threaded knob for easy use.

Item No.	Retaining Force N (reference value)	Knob Tightening Torque N·m	Weight (g)
MR-20CLP	7 or below	0.05 or below	22.6

No.	Material	Material	Finish
①	Plate	304 Stainless Steel	Barrel Polished
②	Knob Body	303 Stainless Steel	Plain
③	Knob Tip	Polyacetal (POM)	Black