

# LEVELING GLIDES \*Special Order Item

# MDSF

CASTERS & LEVELING GLIDES

LEVELING GLIDES



MDSF80-20-100

MDSF58-16-80

MDSF58-10-40

- Glide absorbs shock to reduce movement transmitted to cabinets and equipment, reducing damage to objects within the cabinet as well as those in the surrounding area.
- Keeps aisles and emergency exits clear by reducing the risk of falling furniture or equipment.
- Can be used in raised/access flooring where floor anchors cannot be used.
- Similar installation and appearance to traditional glides, but with value-added function and higher cost performance.
- 2-step shock absorption: internally between bolt and glide base, and externally between glide base and flooring.
- Use with computer server racks, precision equipment, medical equipment, etc.
- Sold in sets of 4 pieces.

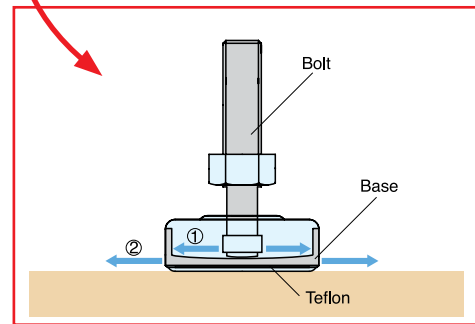
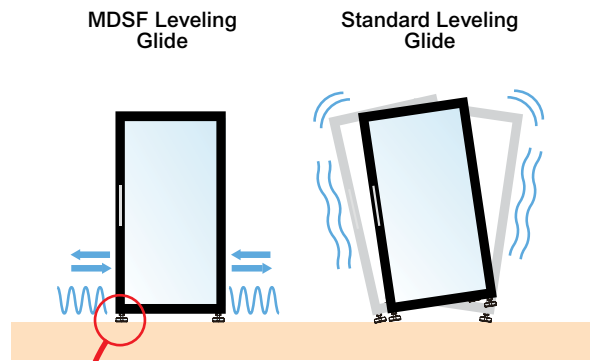
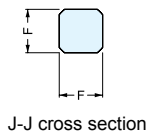
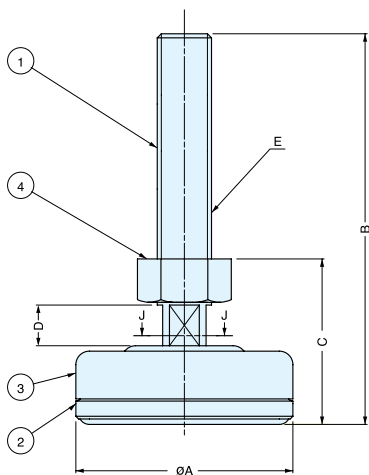
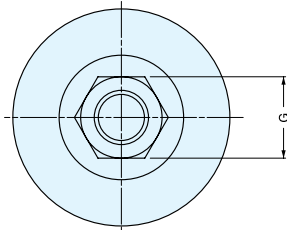

No.	Part Name	Material	Finish
①	Bolt	Steel	Nickel
②	Base	Steel, Teflon	
③	Cover	NBR	
④	Nut	Steel	Chromate

Item No.	Max. Recommended Dimensions (WxDxH)	Maximum Weight /4pcs
MDSF58-10-40	16-1/8"x24-13/16"x15-3/8" (410x630x390 mm)	450 lbs (204 kg)
MDSF58-16-80	28-3/4"x28-3/4"x57-1/2" (730x730x1460 mm)	1122 lbs (510 kg)
MDSF80-20-100	39-3/8"x39-3/8"x78-3/4" (1000x1000x2000 mm)	1687 lbs (765 kg)

Item No.	A	B	C	D	E	F	G	Weight (g)	Box (pcs)	Carton (pcs)
MDSF58-10-40	2-9/32" (58 mm)	2-19/32" (66 mm)	1-3/8" (35 mm)	5/16" (8 mm)	M10	5/16" (8 mm)	21/32" (17 mm)	180	4 (1 set)	40 (10 sets)
MDSF58-16-80	2-9/32" (58 mm)	4-1/2" (114 mm)	1-7/8" (48 mm)	7/16" (11 mm)	M16	1/2" (13 mm)	15/16" (24 mm)	300		
MDSF80-20-100	3-1/8" (3-5/32")	4-1/2" (114 mm)	2-13/32" (61 mm)	19/32" (15 mm)	M20	5/8" (16 mm)	1-3/16" (30 mm)	580		