

MAGNETIC CATCH



MC0099

CATCHES & LATCHES

MAGNETIC CATCHES / STRONG MAGNETIC CATCHES

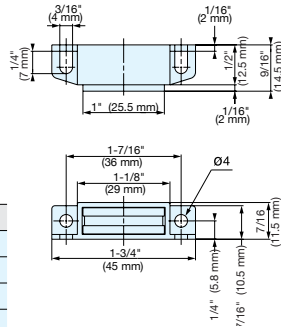

- Special design provides screw mounting options in 2 different planes.
- Three different magnetic forces available.
- Strike available (sold separately).

Material	Finish/Color
ABS	Black (BLK), White (WHT)
Polycarbonate	Grey (GR)
Steel	Yellow Zinc Chromate
Ferrite	-

Strike Plate (Sold separately)

Item No.	Material	Finish
SP0207	Steel	Chromate

Item No.		Magnetic Force	Weight (g)	Box (pcs)	Carton (pcs)
Black	White				
MC0099/BLK	MC0099/WHT	2.4 lbs (1.1 kg)	16.3	100	1000
MC0099S/BLK	MC0099S/WHT	8.3 lbs (3.8 kg)			
MC0099/GR(Grey)		11.4 lbs (5.2 kg)			

STRONG MAGNETIC CATCH



MC-110NF

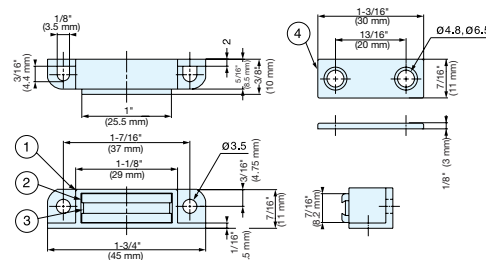

- Special design provides screw mounting options in 2 different planes.
- Strong magnetic force in a small casing.

Item No.	Magnetic Force	Weight (g)	Box (pcs)	Carton (pcs)
MC-110NF/WHT	17.6 lbs (8 kg)	10	100	800
MC-110NF/GR				

No.	Part Name	Material	Finish/Color
①	Housing	Polycarbonate	White (WHT), Grey (GR)
②	Yoke	Steel	Yellow Zinc Chromate
③	Magnet	Neodymium	Nickel
④	Counterplate	Steel	Yellow Zinc Chromate

MAGNETIC CATCH



MC-0051

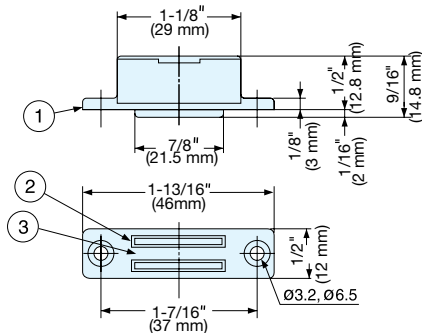

Strike Plate (Sold separately)

Item No.	Material	Finish
SP0207	Steel	Chromate

Item No.	Magnetic Force	Weight (g)	Box (pcs)	Carton (pcs)
MC-0051	12 lbs (5.5 kg)	17	50	500

No.	Part Name	Material	Finish/Color
①	Housing	ABS	Black
②	Yoke	Steel	Chromate
③	Magnet	Ferrite	-