

ULTRA THIN MAGNETIC CATCH



MC-421



• Unique ultra thin magnetic catch design with extra strong magnetic force

- Note: 1) To avoid breakage, counterplate should not hit magnet.
 2) Screw heads should not protrude above the base plate.
 3) Max temperature; 80°C (176°F)
 4) Screws not included, use M3 flat head or equivalent.
 5) Counterplate MC-159-Plate sold separately.

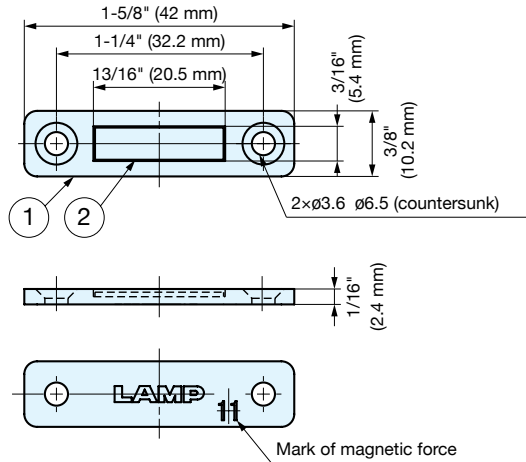

Item No.	Magnetic Force	Weight (g)	Box (pcs)	Carton (pcs)	No.	Part Name	Material	Finish
MC-421-11	2.5 lbs (1.14 kg)	6.4	250	1500	①	Body	Steel	Nickel
MC-421-30	6.8 lbs (3.1 kg)	6.6			②	Magnet	Neodymium	

ULTRA THIN STAINLESS STEEL MAGNETIC CATCH



MC-421SUS



• Unique ultra thin magnetic catch design with extra strong magnetic force

- Note: 1) To avoid breakage, counterplate should not hit magnet.
 2) Screw heads should not protrude above the base plate.
 3) Max temperature; 80°C (176°F)
 4) Screws not included, use M3 flat head or equivalent.
 5) Counterplate MC-159-Plate sold separately.

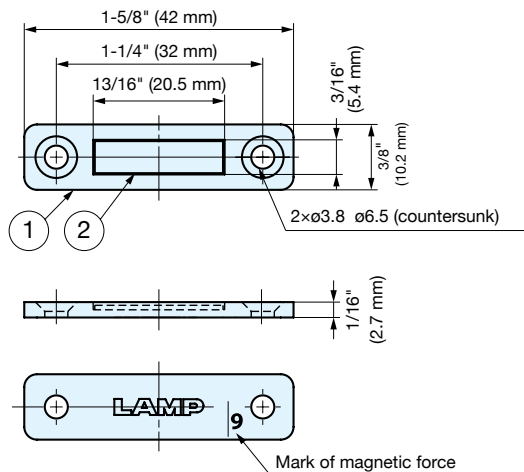

Item No.	Magnetic Force (kg)	Weight (g)	Box (pcs)	Carton (pcs)	No.	Part Name	Material	Finish
MC-421SUS-9	2 lbs (0.9 kg)	6.9	250	1500	①	Body	430 Stainless Steel	Polished
MC-421SUS-24	5.3 lbs (2.4 kg)	7.1			②	Magnet	Neodymium	Nickel