

# SWINGING HANGER

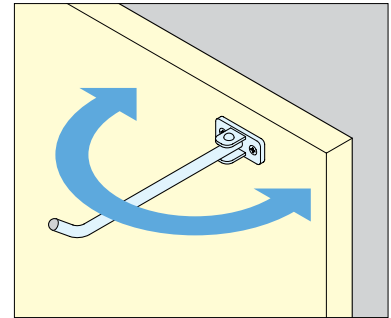

# HM-250Y

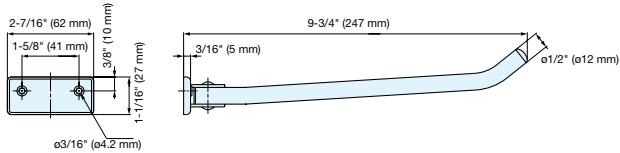

| Item No. | Load Capacity  | Weight (g) | Box (pcs) | Carton (pcs) | Material            | Finish |
|----------|----------------|------------|-----------|--------------|---------------------|--------|
| HM-250Y  | 6.6 lbs (3 kg) | 125        | 10        | 100          | 304 Stainless Steel | Satin  |

# SWINGING HANGER



# HM-250V

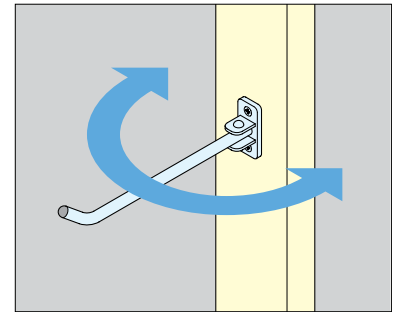
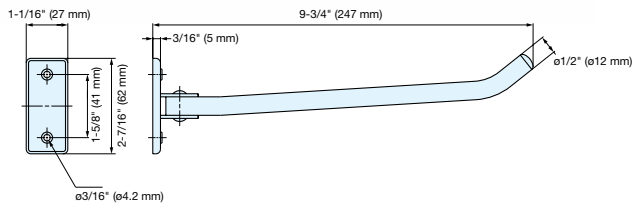

| Item No. | Load Capacity (kg) | Weight (g) | Box (pcs) | Carton (pcs) | Material            | Finish |
|----------|--------------------|------------|-----------|--------------|---------------------|--------|
| HM-250V  | 6.6 lbs (3 kg)     | 120        | 10        | 100          | 304 Stainless Steel | Satin  |

# SWINGING HANGER



# HM-330

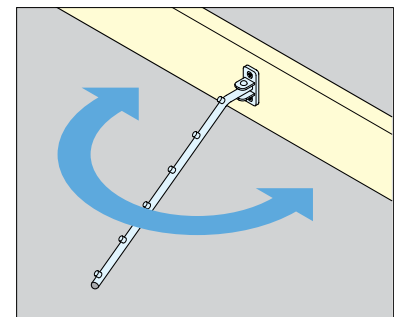
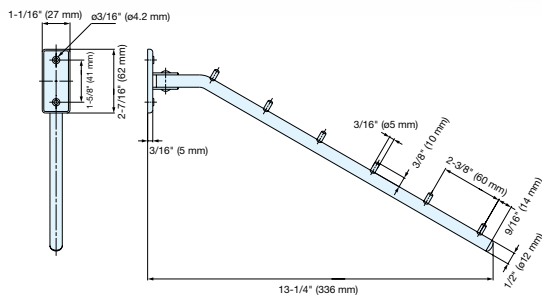

| Item No. | Load Capacity (kg) | Weight (g) | Box (pcs) | Carton (pcs) | Material            | Finish |
|----------|--------------------|------------|-----------|--------------|---------------------|--------|
| HM-330   | 6.6 lbs (3 kg)     | 170        | 10        | 100          | 304 Stainless Steel | Satin  |