

TWIN WHEEL CASTER (PLATE TYPE)



GX-75-PS, P



GX-75-PS
(w/ Brake)



GX-75-P
(w/o Brake)

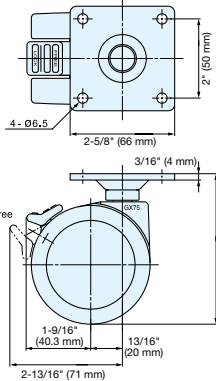
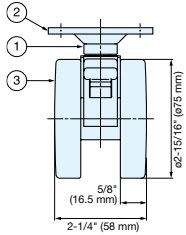

- Heavy duty and low profile.
- Twin wheel caster with excellent stability.

Item No.	Type	Load Capacity	Weight (g)	Box (pcs)	Carton (pcs)
GX-75-PS	w/ Brake	438 lbs (200 kg)	445	2	24
GX-75-P	w/o Brake	438 lbs (200 kg)	430		

No.	Part Name	Material	Finish
①	Body	Aluminum Alloy	Polished
②	Mounting Plate	Steel	Zinc Chromate
③	Wheel	Polyamide	Black

TWIN WHEEL CASTER (NON-SWIVEL)



GX-W50K

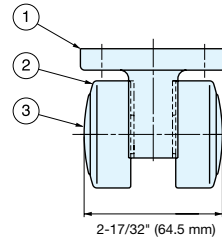
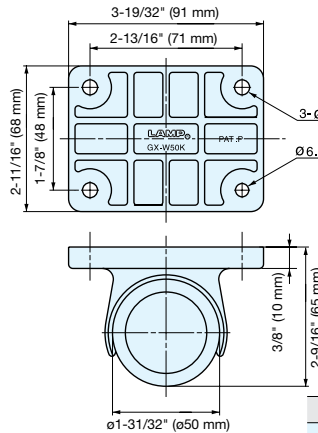

- Non-swivel (fixed) caster.
- Heavy duty and low profile.
- Twin wheel caster with excellent stability.
- Use in combination with GX-W50GN12, GN16 or GP (Swivel Type) for easy handling.

Item No.	Load Capacity	Weight (g)	Box (pcs)	Carton (pcs)
GX-W50K	441 lbs (200 kg)	300	2	48

No.	Part Name	Material	Finish
①	Body	Aluminum Alloy	Polished
②	Wheel	Polyacetal	Black
③	Cover	Polyamide	

TWIN WHEEL CASTER (THREADED BOLT & PLATE)



GX-W50GN12, GN16, GP



GX-W50GN12, GN16
(Threaded bolt type)

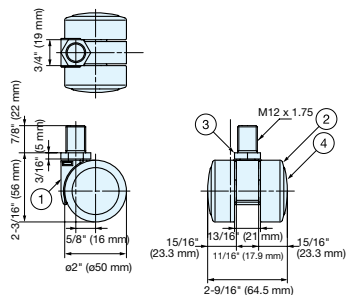

GX-W50GN12, GN16

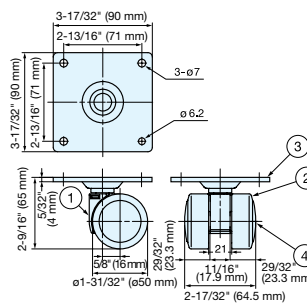

GX-W50GP

- Swivel type, heavy duty and low profile.
- Twin wheel caster with excellent stability.
- Use in combination with GX-W50K (Non-swivel type) for easy handling.
- Threaded bolt or plate type available.

Item No.	d	S	Load Capacity	Weight (g)	Box (pcs)	Carton (pcs)
GX-W50GN12	M12 x 1.75	19	441 lbs (200 kg)	208	4	80
GX-W50GN16	M16 x 2.0	21		223		
GX-W50GP	-	-		420		

No.	Part Name	Material	Finish
①	Body	Aluminum Alloy	Polished
②	Wheel	Polyacetal	Black
③	Threaded Bolt Mounting Plate (GP)	Steel	Yellow Zinc Chromate
④	Cover	Polyamide	Black