

TWIN WHEEL CASTER (PLATE TYPE)

LOAD CAPACITY
100 kg
220 lbs

TEST 13
P.698



GX-50-PS, P

- Heavy duty and low profile.
- Twin wheel caster with excellent stability.



GX-50-PS
(w/ Brake)

GX-50-P
(w/o Brake)

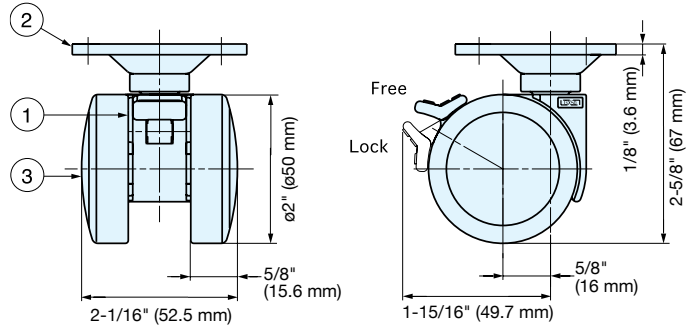

Item No.	Type	Load Capacity	Weight (g)	Box (pcs)	Carton (pcs)
GX-50-PS	w/ Brake	220 lbs (100 kg)	235	4	72
GX-50-P	w/o Brake	220 lbs (100 kg)	230		

No.	Part Name	Material	Finish
①	Body	Aluminum Alloy	Polished
②	Mounting Plate	Steel	Yellow Zinc Chromate
③	Wheel	Polyamide	Black

TWIN WHEEL CASTER (THREADED BOLT TYPE)

LOAD CAPACITY
100 kg
220 lbs

TEST 13
P.698

GX-50-N12S, N12

- Heavy duty and low profile.
- Twin wheel caster with excellent stability.



GX-50-N12S
(w/ Brake)

GX-50-N12
(w/o Brake)

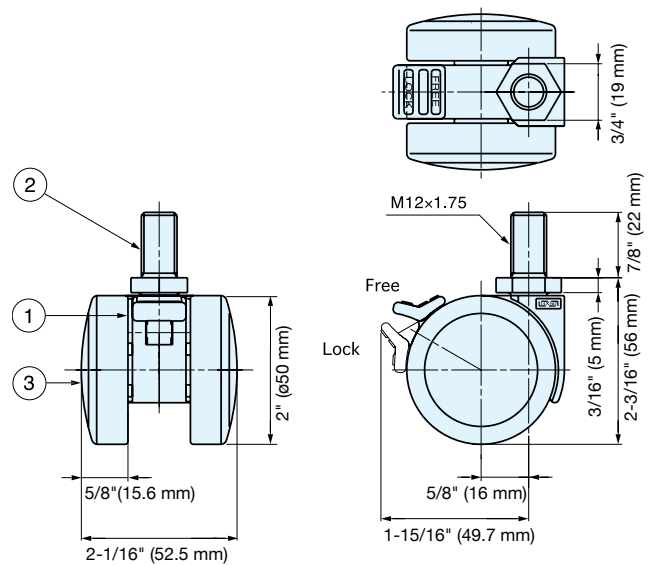

Item No.	Type	Load Capacity	Weight (g)	Box (pcs)	Carton (pcs)
GX-50-N12S	w/ Brake	220 lbs (100 kg)	175	4	72
GX-50-N12	w/o Brake	220 lbs (100 kg)	170		

No.	Part Name	Material	Finish
①	Body	Aluminum Alloy	Polished
②	Threaded Bolt	Steel	Yellow Zinc Chromate
③	Wheel	Polyamide	Black