

GLASS DOOR CAM LOCK

GS-GL50

- A cylinder lock for high-end glass showcases.
- Designed for use with the GS-GH50 hinge, complements retail fixtures.
- Thick stainless steel deadbolt for added security.
- The keys are dimple type and reversible.
- Key number can be changed without replacing the cylinder (Easy key change).
- The key number can be changed up to 2 times. Previous keys cannot be used again after changing the key number.
- A cover hides the key hole.
- The face plate can be used as a handle to open the door.
- The only drilling required for the cabinet is a round hole. This makes the installation very quick.
- Special type which does not have the construction key system is also available (Key changes: 3,000 per master key).

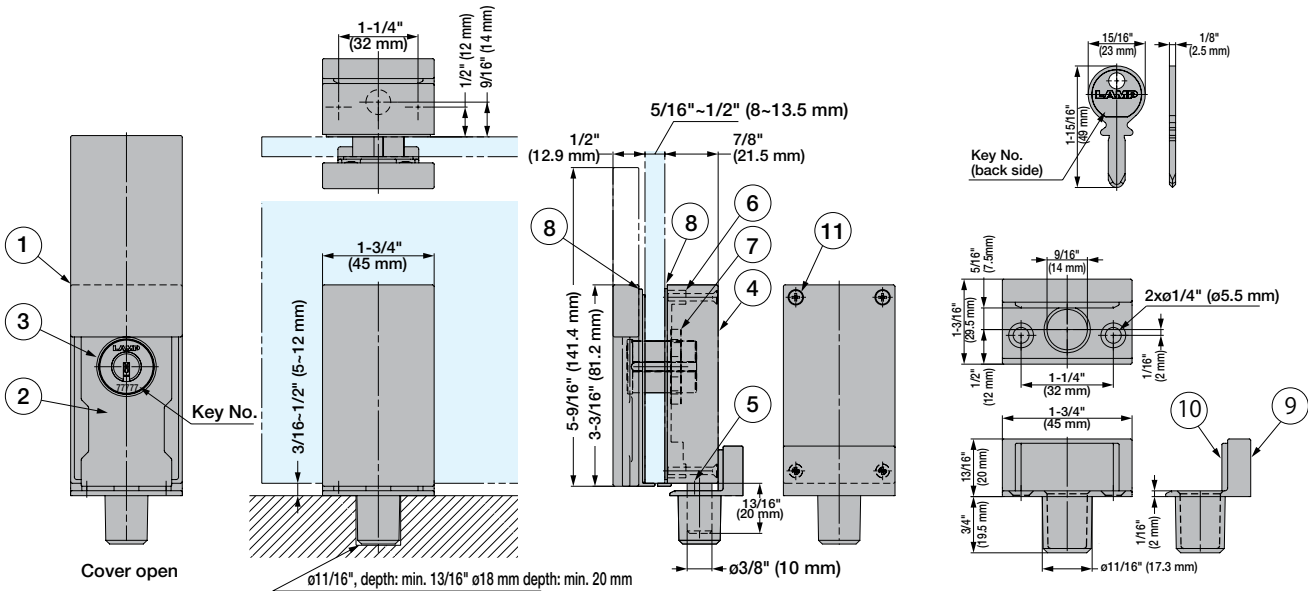

Cut Out Dimensions

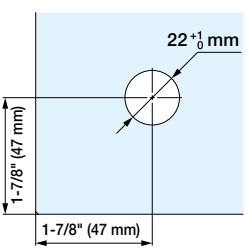

No.	Part Name	Material	Finish		
			CR	GP	BL
1	Slide Cover	Zinc Alloy (ZDC)	Chrome	Gold Plated (24K)	Enamel Black
2	Face Plate				
3	Cylinder	Brass			
4	Case Lock	Zinc Alloy (ZDC)			
5	Dead Bolt	Stainless Steel	Plain		
6	Back Plate	Zinc Alloy (ZDC)			
7	Nut	Brass	Nickel		
8	Packing	Chloroprene Rubber (CR)	Black		
9	Strike Plate	Zinc Alloy (ZDC)	Chrome	Gold Plated	Enamel Blk
10	Strike Plate Rubber	EPDM	Black		
11	Countersunk Screw M3 x 18	-	Chrome	Gold Plated	Enamel Blk

Item Name	Glass Thickness	Finish
GS-GL50-CR	5/16-1/2" (8-13.5 mm)	Chrome
GS-GL50-GP		Gold Plated
GS-GL50-BL		Black