

TWIN WHEEL CASTER (THREADED BOLT TYPE)



FP-45-NS, N



FP-45-NS
(w/ Brake)

FP-45-N
(w/o Brake)

• Caster with high quality polyamide body. Excellent durability, chemical/weather/wear resistance.

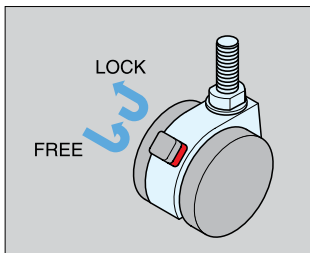
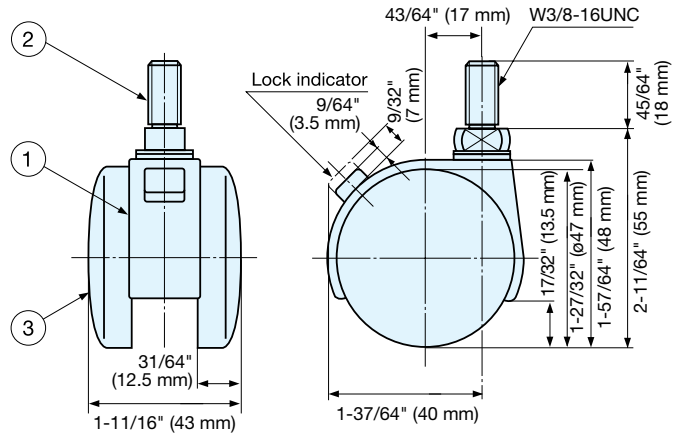

Item No.	Type	d	Load Capacity	Weight (g)	Box (pcs)	Carton (pcs)
FP-45-NS	w/ Brake	W3/8-16UNC	88 lbs (40 kg)	84	4	100
FP-45-N	w/o Brake	W3/8-16UNC	88 lbs (40 kg)	79		

No.	Part Name	Material	Finish
①	Body	Polyamide	Black
②	Threaded Bolt	Steel	Yellow Zinc Chromate
③	Wheel	Polyamide	Black

TWIN WHEEL CASTER (PLATE TYPE)



FP-55-PS, P



FP-55-PS
(w/ Brake)

FP-55-P
(w/o Brake)

• Caster with high quality polyamide body. Excellent durability, chemical/weather/wear resistance.

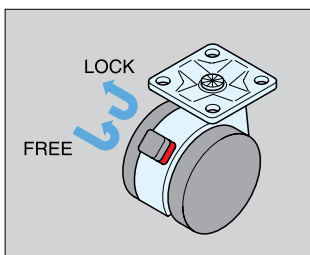
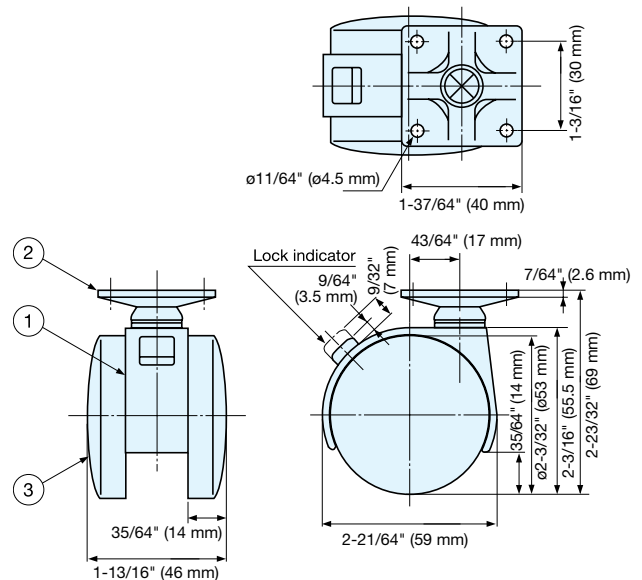

Item No.	Type	Load Capacity	Weight (g)	Box (pcs)	Carton (pcs)
FP-55-PS	w/ Brake	110 lbs (50 kg)	133	4	72
FP-55-P	w/o Brake	110 lbs (50 kg)	128		

No.	Part Name	Material	Finish
①	Body	Polyamide	Black
②	Mounting Plate	Steel	Yellow Zinc Chromate
③	Wheel	Polyamide	Black