

CASTER WITH LEVELING GLIDE



AF-50, 65

CASTERS & LEVELING GLIDES

CASTERS WITH LEVELING GLIDES



- Heavy duty, low profile caster with built-in leveling glide.
- Allows solid support by leveler once equipment is in place.
- Simplifies mounting as leveler is integrated with caster.

Semiconductor Equipment

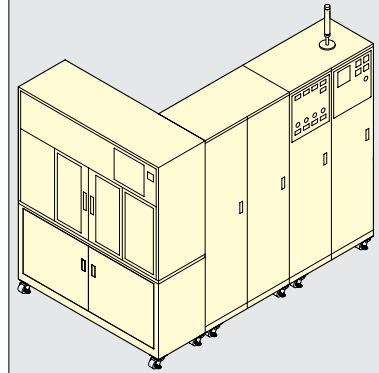

Garbage Container

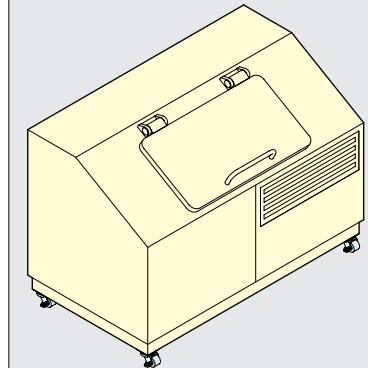

Laser Equipment

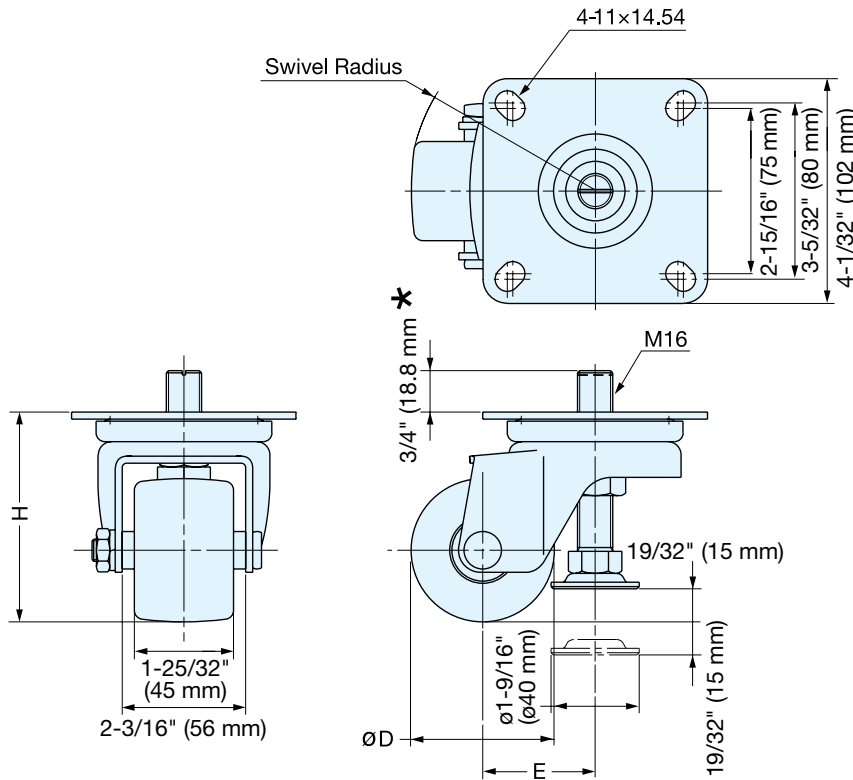
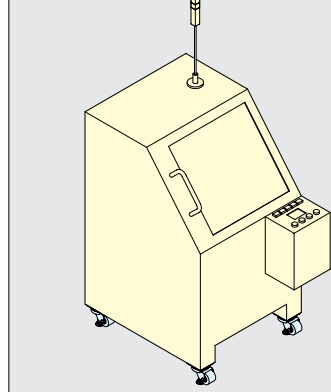

*Round cut out or bore is required for bolt of leveler.

Installation

Part Name	Material	Finish
Body	Steel	Chrome
Wheel	Nylon	Black

Item No.	D	H	E	Swivel Radius	Load Capacity	Weight (g)	Box (pcs)	Carton (pcs)
AF-50	1-31/32" (50 mm)	2-29/32" (74 mm)	1-13/16" (46 mm)	2-7/8" (73 mm)	561 lbs (255 kg)	1205	18	180
AF-65	2-9/16" (65 mm)	3-3/4" (95 mm)	2" (51 mm)	3-11/32" (85 mm)	561 lbs (255 kg)	1335	12	120