

PUSH LOCK FASTENER (LARGE/FLUSH TYPE)

251F, 151F

CATCHES & LATCHES

PUSH LOCK FASTENERS



- 2 piece fastener allows for fast and easy access with complete removal of panel.
- Attach socket into outer panel/plug into removable panel.
- Insert plug into socket and push to lock/unlock.
- Flush locked design prevents snagging.
- Fastens plastic or sheet metal panels.

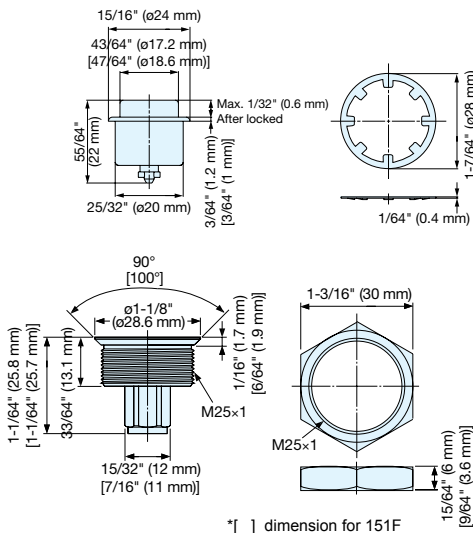
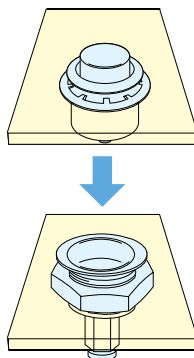

■ Preparation (Plug)

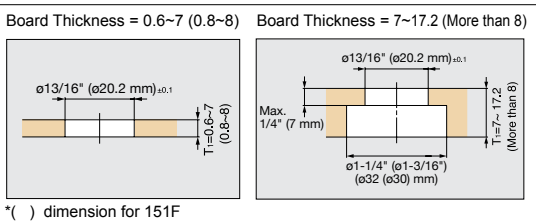

■ Preparation (Socket)

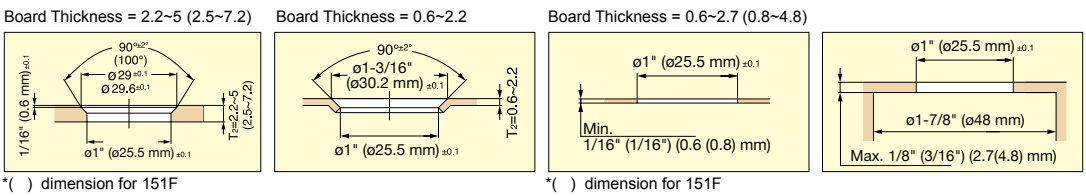

■ Grip Dimensions

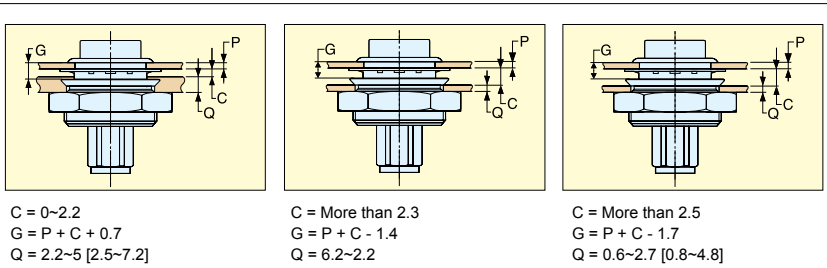

■ 251F

No.	Part Name	Material	Finish
①	Plug	Polyacetal	Black
②	Ring	Steel	
③	Socket	Polyacetal	
④	Nut		

■ 151F

No.	Part Name	Material	Finish
①	Plug	Brass	Chrome
②	Ring	Steel	Plain
③	Socket	Brass	Chromate
④	Nut	Zinc Alloy	

Item No.	Grip Dimension G	Plug Dimension L	Retaining Force	Weight (g)
251F-01-3	1/16"~3/32" (1.2~2.0 mm)	20.5	55 lbs (25 kg)	15
251F-02-3	3/32"~ 1/8" (2.0~2.8 mm)	21.0		
251F-03-3	1/8"~ 9/64" (2.8~3.6 mm)	22.0		
251F-04-3	9/64"~5/32" (3.6~4.4 mm)	23.0		
251F-05-3	5/32"~3/16" (4.4~5.2 mm)	23.5		
251F-06-3	3/16"~1/4" (5.2~6.0 mm)	24.5		

Item No.	Grip Dimension G	Plug Dimension L	Retaining Force	Weight (g)
151F-01-2	1/16"~3/32" (1.2~2.0 mm)	20.5	55 lbs (25 kg)	51
151F-02-2	3/32"~ 1/8" (2.0~2.8 mm)	21.0		
151F-03-2	1/8"~ 9/64" (2.8~3.6 mm)	22.0		
151F-04-2	9/64"~5/32" (3.6~4.4 mm)	23.0		
151F-05-2	5/32"~3/16" (4.4~5.2 mm)	23.5		
151F-06-2	3/16"~1/4" (5.2~6.0 mm)	24.5		