

CABLE GROMMET (VAPOR PROTECTION)



WSM-150



- Cable grommet with oil/vapor barrier.
 - Grommet cover can be installed/uninstalled without tools.
 - Cable grommet designed for variety of manufacturing tool and equipment enclosures.
 - IP54F rated - limits the ingress of dust and fluid sprays.
 - Accommodates cables up to Ø30 mm.
 - Gasket can be adjusted to accommodate multiple cables.
 - Wiring maintenance can be done without tools.
 - WSM-10 cable management bracket optional.
- For best performance, the grommet should be installed at the base of the enclosure.

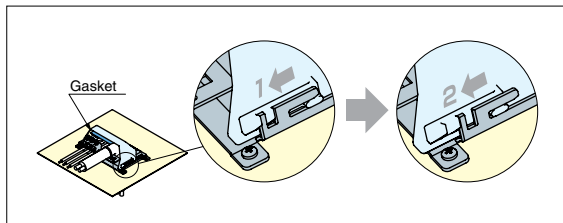
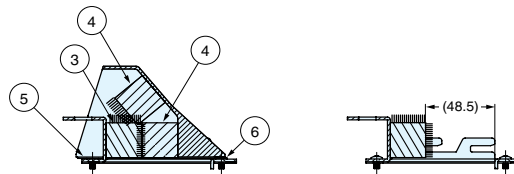
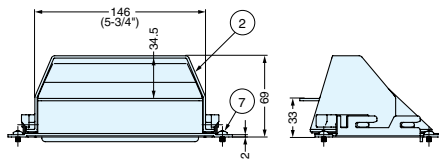
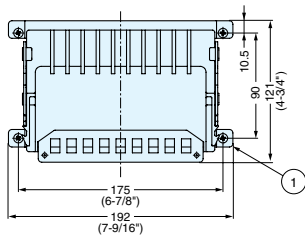
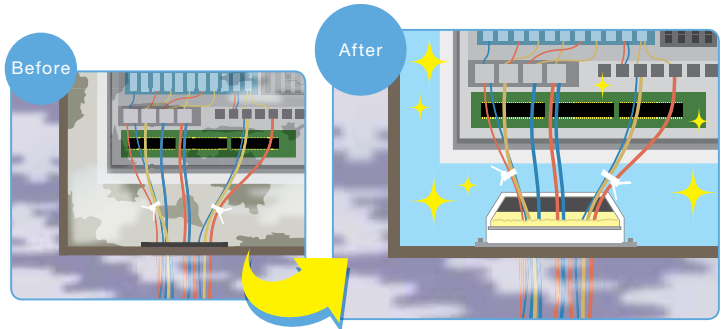
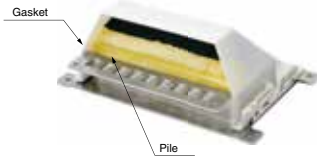

WSM-150

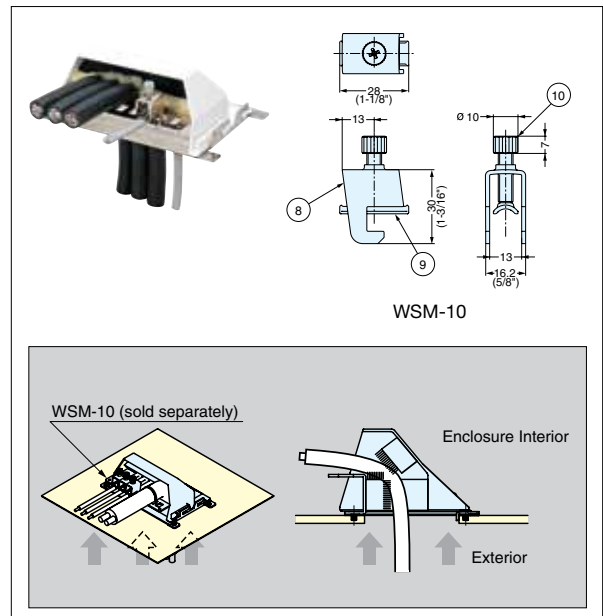

WSM-10

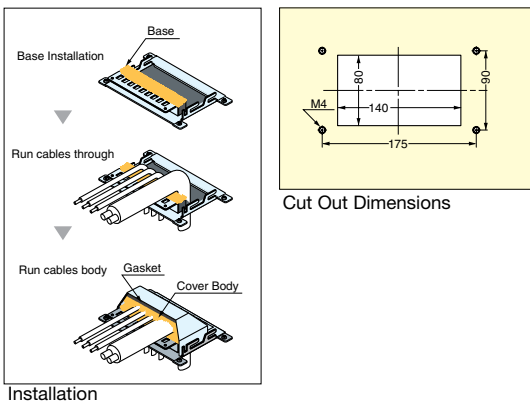

Installation

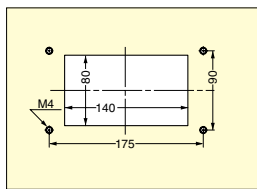

Cut Out Dimensions

No.	Part Name	Material	Finish
①	Body	Steel	Nickel
②	Cover	ABS	White
③	Gasket A	NBR rubber+pile fabric	Black
④	Gasket B		
⑤	Gasket C	NBR rubber	Plane
⑥	Gasket D		
⑦	Screw	Stainless Steel	

Item No.	Description	Weight (g)
WSM-150	Cable Grommet	438
WSM-10	Wire management bracket	23