

MONITOR ARM

- Tilt angle can be adjusted in 10° increments while the button is pressed.
- The back lever allows for height adjustment in 1" (25 mm) increments (4 levels).
- Features a friction mechanism which prevents against accidental release.
- Applicable monitor size: 12" - 22.9" (304.8 mm - 581.7 mm) Weight: Max. 22 lbs (10 kg)
- Monitor mounting holes VESA compliant (75 mm x 75 mm and 100 mm x 100 mm)

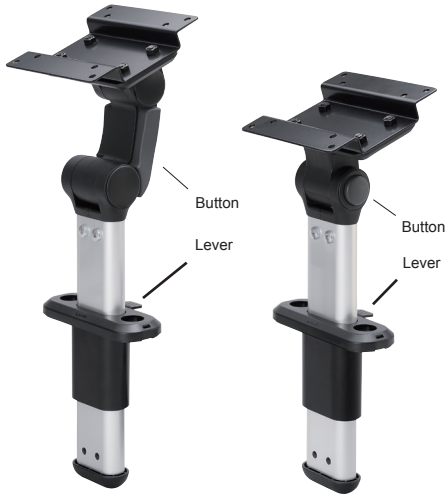

Dual axis type

Single axis type

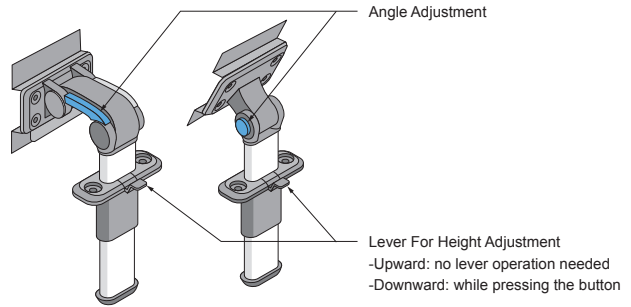

KA-TLG2-100

KA-TLG1-100

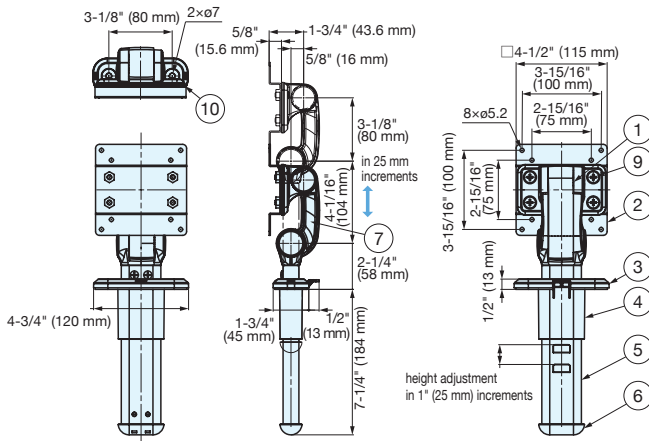

KA-TLG2-100

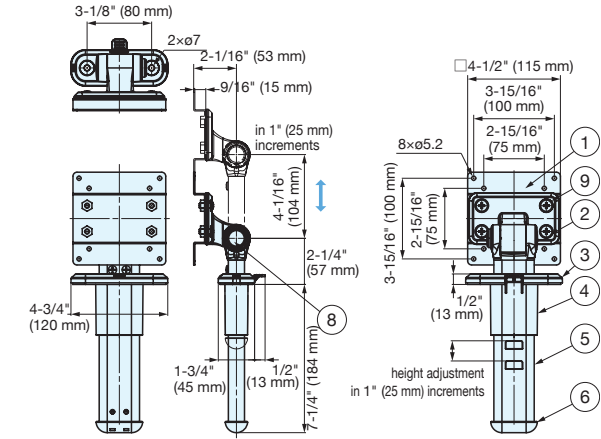

KA-TLG1-100

Cut Out Dimensions

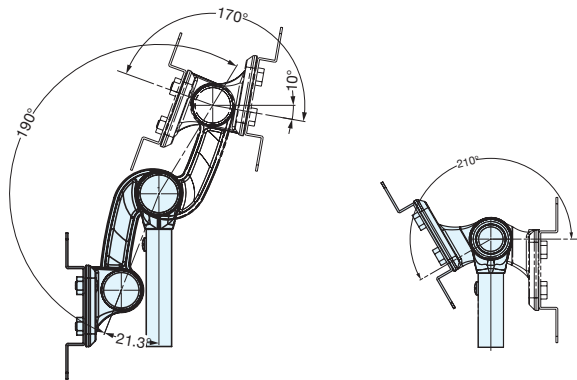
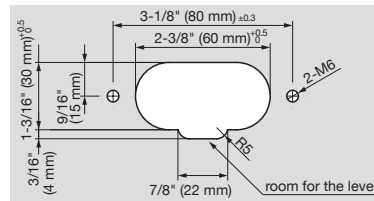

KA-TLG2-100 (Dual Axis)

KA-TLG1-100 (Single Axis)

No.	Part Name	Material	Finish
①	Bracket	Polyamide (PA)	Black
②	Mounting Plate	Steel (SPHC)	
③	Cover	Polycarbonate	
④	Outer Pipe	ABS	
⑤	Aluminium Pipe	Aluminium Alloy	Anodized
⑥	End Cap	ABS	Black
⑦	Button	Polyamide (PA)	Grey
⑧	Button	ABS	
⑨	Cross-recessed trus head screw	Steel	Black Chromate
⑩	Packing	Nitrile Rubber (NBR)	Black

Item No.	Axis	Vertical Load Capacity (kgf)	Allowable Moment (kgf-cm)	Weight (g)	Box (pcs)
KA-TLG2-100	Dual	22.4 lbs. (10.2)	132.7 lbs-in (153)	705	1
KA-TLG1-100	Single			545	