

HEAT RESISTANT TORQUE HINGE



HG-ITHP

HINGES

HEAT RESISTANT TORQUE HINGE

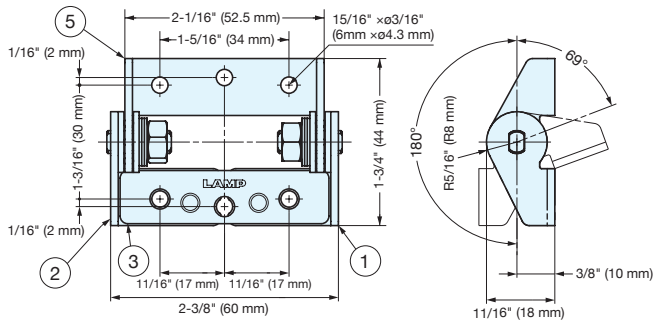
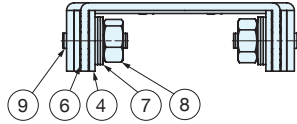
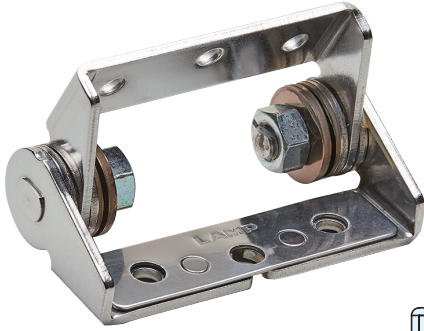

Free stop
Heat resistant

- Suitable for use in heat-generating environments. Mounts externally to the machinery.
- Operating temperature: 32°F~212°F
- Recommended for dryers, lighting equipment, temperature chambers, food processing equipment.
- Ideal solution to replace spring hinges that cannot free stop at any angle.
- When installing, ensure that both hinge shafts are leveled and aligned.

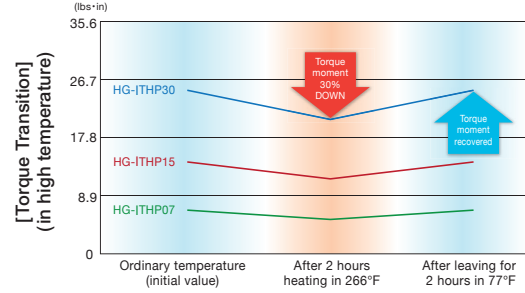

Torque may decrease during and after heating, and it will restore when returning to normal temperature.

No.	Part Name	Material	Finish
①	Base L	304 Stainless Steel	-
②	Base R		
③	Connecting Bracket		
④	Thrust Plate	Carbon Steel	-
⑤	Movable Bracket	304 Stainless Steel	-
⑥	Ball	Steel	-
⑦	Spring Washer	Stainless Steel	-
⑧	Hexagon Nut	Steel	Zinc Chromate (Trivalent)
⑨	Shaft	303 Stainless Steel	-

Item No.	Torque per piece	Weight (g)	Box (pcs)	Carton (pcs)
HG-ITHP07	6.2 lbs·in	70	25	100
HG-ITHP15	13.3 lbs·in	70	25	100
HG-ITHP30	26.6 lbs·in	72	25	100