

PARTS SEPARABLE CASTER (W/GLIDE)



CA



CABF-75/BLK



CAPS-50/WHT

- Special order item.
- Built-in leveling glide allows easy installation rather than installing two separate parts.
- Glides provide better stability than regular caster with stopper.
- Caster body rotates freely when raised by the glide. Tighten fixing screw to fix the position.
- Parts can be easily separated for recycling purpose.

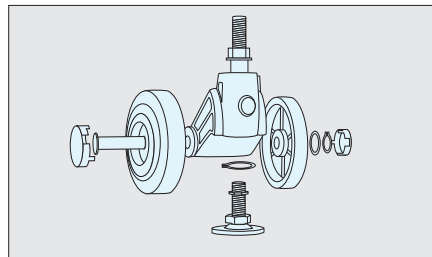
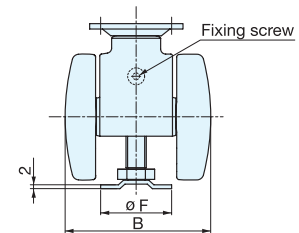
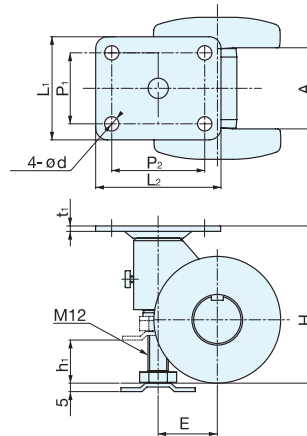
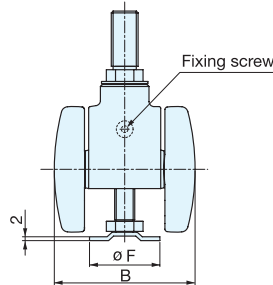
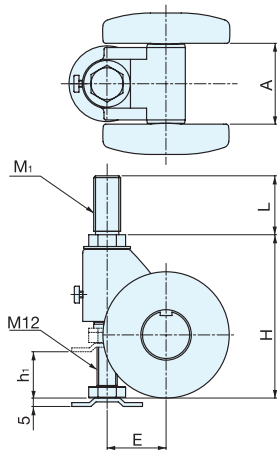

• Parts can be easily separated for recycling purpose.

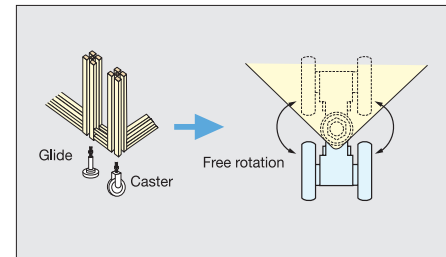

- Built-in leveling glide allows easy installation rather than installing two separate parts.
- Caster body rotates freely when raised by the glide. Tighten fixing screw to fix the position.

Part Name	Material	
	CABF, CAPF	CABS, CAPS
Body / Wheel	Polyamide (Black, White)	Polyamide (White)
Glide	Steel (Yellow Zinc Chromate)	304 Stainless Steel (Passivated)
Threaded Bolt Plate		

Item No.		Type	H	h ₁	E	F	A	B	L	L ₁	L ₂	P ₁	P ₂	d	t ₁	M ₁	Load Capacity (kg)	Weight (g)	Box (pcs)	Carton (pcs)
Black	White																			
CABF-50/BLK	CABF-50/WHT	Stem	67	10	30	34	40	69	35	-	-	-	-	-	-	M12	60 (132 lbs)	260	40	400
CABF-75/BLK	CABF-75/WHT		95	24	35	42	50	84								M16	120 (264 lbs)	400	20	200
-	CABS-50/WHT		67	10	30	34	40	69								M12	60 (132 lbs)	262	40	400
-	CABS-75/WHT		95	24	35	42	50	84								M16	120 (264 lbs)	402	20	200
CAPF-50/BLK	CAPF-50/WHT	Plate	63	10	30	34	40	69	-	61	74	42	55	8.5	3.2	-	60 (132 lbs)	306	40	400
CAPF-75/BLK	CAPF-75/WHT		92	24	35	42	50	84									120 (264 lbs)	424	20	200
-	CAPS-50/WHT		63	10	30	34	40	69									60 (132 lbs)	300	40	400
-	CAPS-75/WHT		92	24	35	42	50	84									120 (264 lbs)	420	20	200