

## TWIN WHEEL CASTER (THREADED BOLT TYPE)

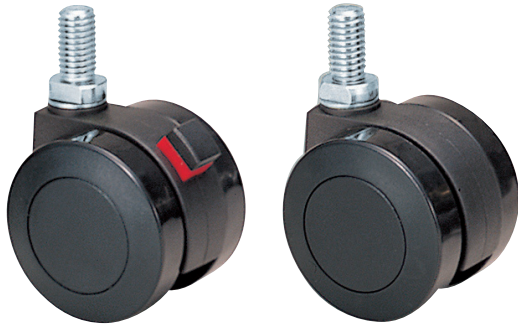

**LOAD CAPACITY**  
40 kg  
88 lbs

## FP-45-NS, N



FP-45-NS  
(w/ Brake)

FP-45-N  
(w/o Brake)

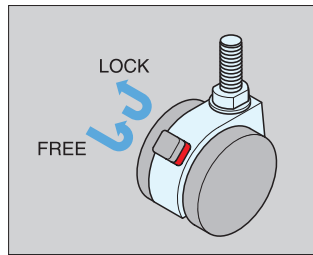

• Caster with high quality polyamide body. Excellent durability, chemical/weather/wear resistance.

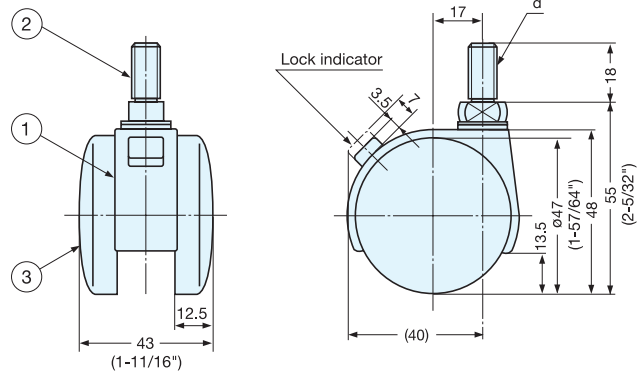

Item No.	Type	d	Load Capacity (kg)	Weight (g)	Box (pcs)	Carton (pcs)
FP-45-NS	w/ Brake	W3/8-16UNC	40 ( 88 lbs )	84	4	100
FP-45-N	w/o Brake	W3/8-16UNC	40 ( 88 lbs )	79		

No.	Part Name	Material	Finish
①	Body	Polyamide	Black
②	Threaded Bolt	Steel	Yellow Zinc Chromate
③	Wheel	Polyamide	Black

## TWIN WHEEL CASTER (PLATE TYPE)



**LOAD CAPACITY**  
50 kg  
110 lbs



## FP-55-PS, P



FP-55-PS  
(w/ Brake)

FP-55-P  
(w/o Brake)

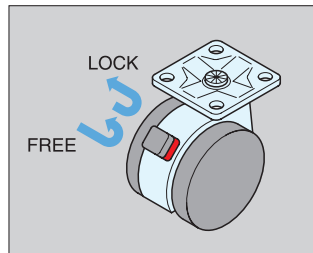

• Caster with high quality polyamide body. Excellent durability, chemical/weather/wear resistance.

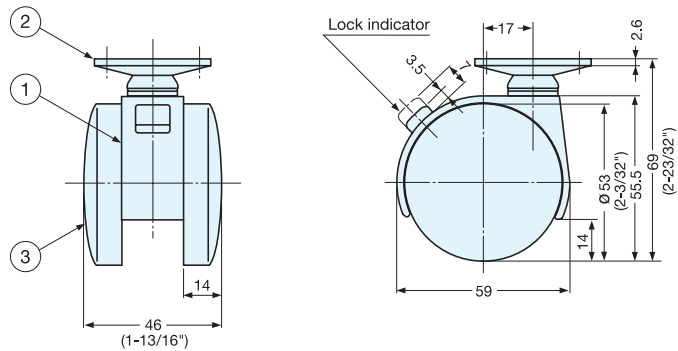

Item No.	Type	Load Capacity (kg)	Weight (g)	Box (pcs)	Carton (pcs)
FP-55-PS	w/ Brake	50 (110 lbs )	133	4	72
FP-55-P	w/o Brake	50 (110 lbs )	128		

No.	Part Name	Material	Finish
①	Body	Polyamide	Black
②	Mounting Plate	Steel	Yellow Zinc Chromate
③	Wheel	Polyamide	Black