

TWIN WHEEL CASTER (PLATE TYPE)



FA-45-PS, P

• Light & durable aluminum body construction.



FA-45-P
(w/ Brake)



FA-45-PS
(w/o Brake)

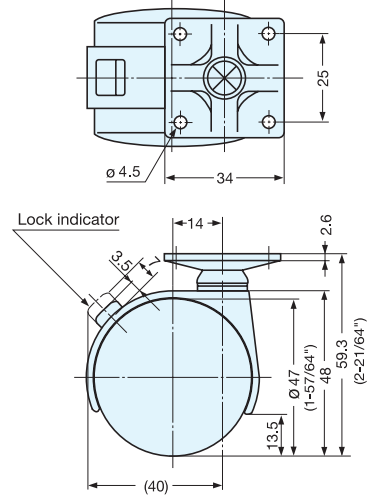
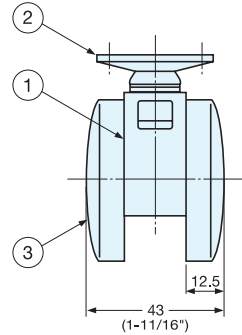
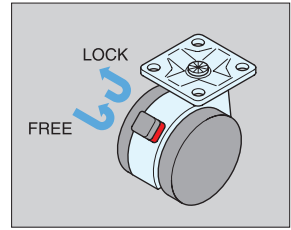

Item No.	Load Capacity (kg)	Weight (g)	Box (pcs)	Carton (pcs)
FA-45-PS	50 (110 lbs)	117	4	100
FA-45-P	50 (110 lbs)	113		

No.	Part Name	Material	Finish
①	Body	Aluminum Alloy	Silver
②	Mounting Plate	Steel	Yellow Zinc Chromate
③	Wheel	Polyamide	Black

TWIN WHEEL CASTER (PLATE TYPE)



FP-45-PS, P

• Caster with high quality polyamide body.
Excellent durability, chemical / weather / wear resistance.



FP-45-P
(w/ Brake)



FP-45-PS
(w/o Brake)

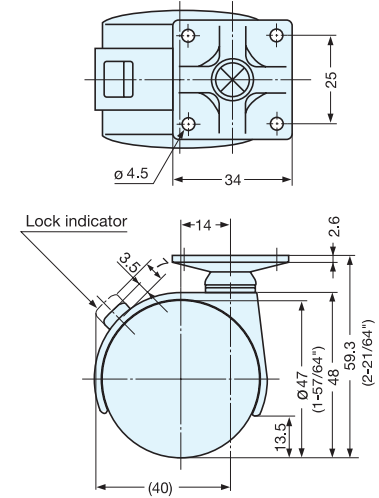
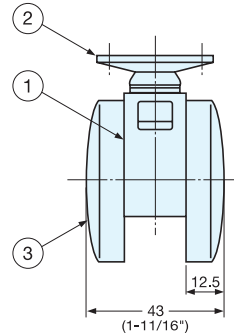
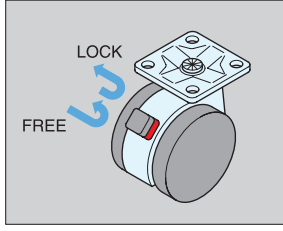

Item No.	Load Capacity (kg)	Weight (g)	Box (pcs)	Carton (pcs)
FP-45-PS	40 (88 lbs)	98	4	100
FP-45-P	40 (88 lbs)	94		

No.	Part Name	Material	Finish
①	Body	Polyamide	Black
②	Mounting Plate	Steel	Yellow Zinc Chromate
③	Wheel	Polyamide	Black