

SWINGING HANGER

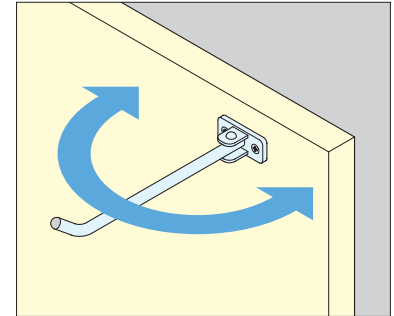

HM-250Y

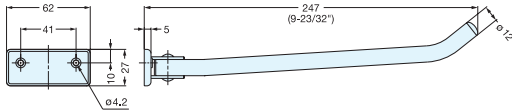
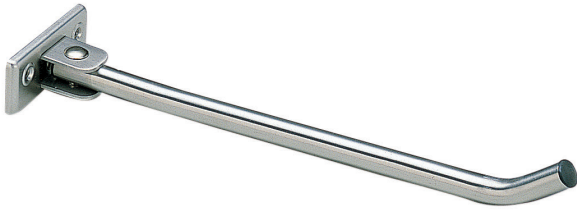

Item No.	Load Capacity (kg)	Weight (g)	Box (pcs)	Carton (pcs)	Material	Finish
HM-250Y	3 (6.6 lbs)	125	10	100	304 Stainless Steel	Satin

SWINGING HANGER



HM-250V

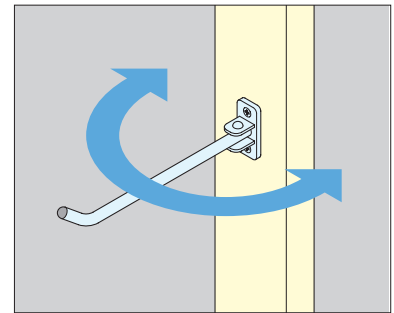
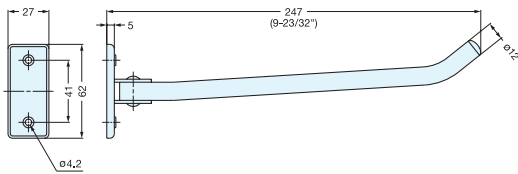
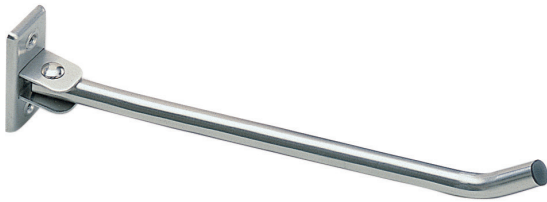

Item No.	Load Capacity (kg)	Weight (g)	Box (pcs)	Carton (pcs)	Material	Finish
HM-250V	3 (6.6 lbs)	120	10	100	304 Stainless Steel	Satin

SWINGING HANGER



HM-330

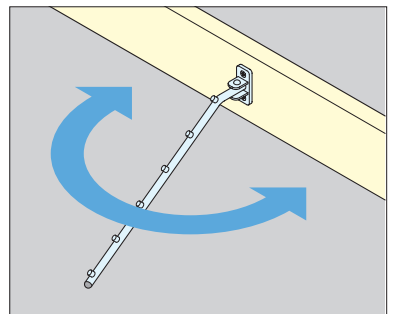
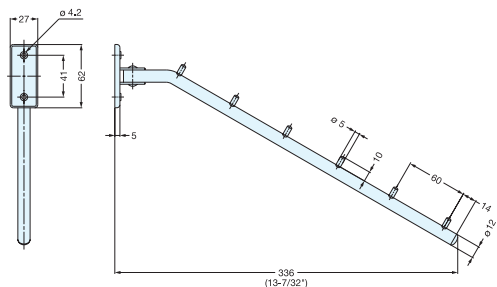
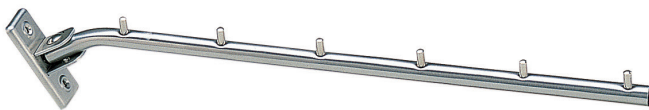

Item No.	Load Capacity (kg)	Weight (g)	Box (pcs)	Carton (pcs)	Material	Finish
HM-330	3 (6.6 lbs)	170	10	100	304 Stainless Steel	Satin