

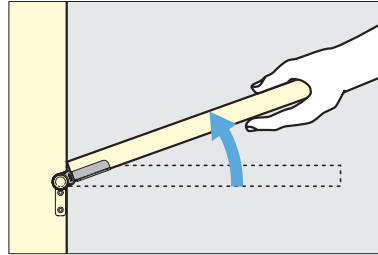

RATCHET HINGE WITH FRICTION

- Ratchet hinge holds at 18 angles in 5° increments from the closed position to the 90° max opened position.
- Lift up to the fully open position 108° to release the ratchet mechanism.
- The friction (resistance) function works when released for safe operation.
- Ideal for adjustable work surfaces such as keyboard trays or desks.
- Max. torque: 354 lbs·in/pair (408kgf·cm/pair).
- Each hinge requires 4 No. 12 (M5.5) flathead countersunk screws for installation (Screws not included).
- Sold in pairs.



Lock Release

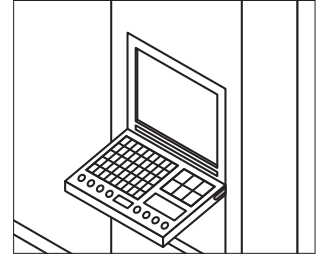

Application Example

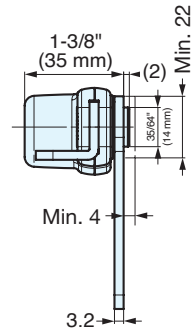
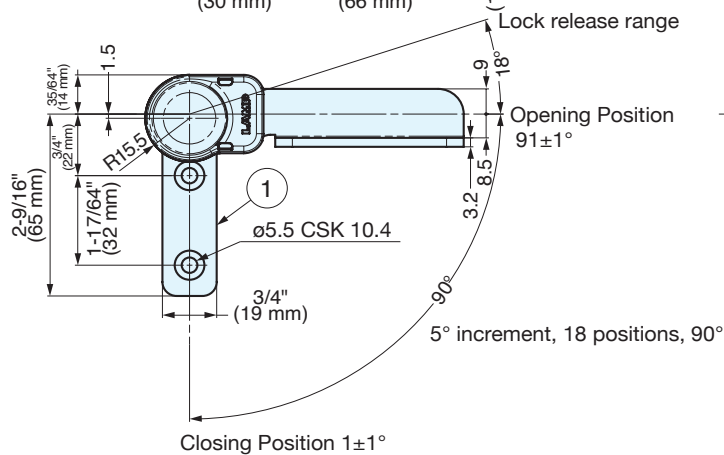
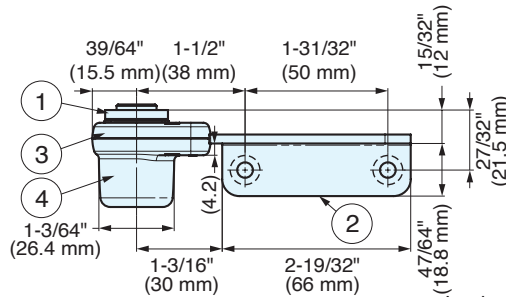
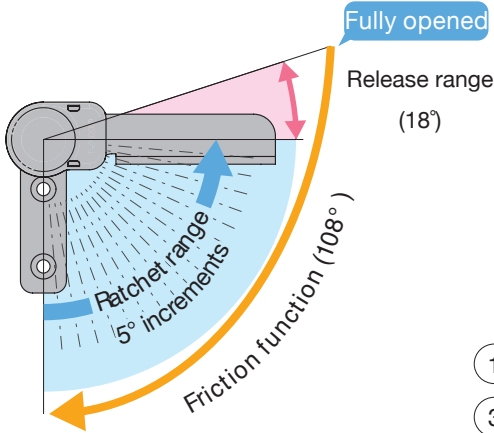

Item No.	Max Torque (kgf·cm/pair)	Weight (g)	Box (pair)	Carton (pair)
HG-RCT12-C	408 (354 lbs·in/pair)	173/pair	8	32

No.	Part Name	Material	Finish
①	Bracket	Steel	Nickel
②	Arm		
③	Cover	Polycarbonate	Light Gray
④	Cover		