

CORNER FASTENER (W/LOCK)

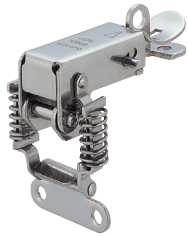

STF-C64A



STF-C64A

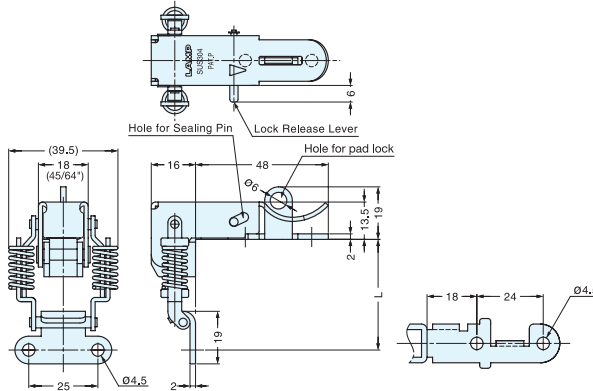

- Designed to allow front operation.
- Locks when fastened to prevent accidental release.
- Pull lever and lift latch to open.
- Door thickness : 14~28 mm (9/16"~1-1/8")

•STF-C64A

L (mm)	Clamping Force kgf±1.5 (lbs±3.3)
40	0
41	6.0 (13.2 lbs)
42	7.3 (16.0 lbs)
43	8.6 (19.0 lbs)
44	9.9 (21.8 lbs)

*Maximum "L" dimension is 44 mm.

Item No.	Spring	Weight (g)	Box (pcs)	Carton (pcs)
STF-C64A	With	66.5	15	210

Material	Finish
304 Stainless Steel	Polished

COMPACT DRAW LATCH



SCC-TF30

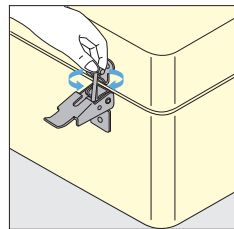
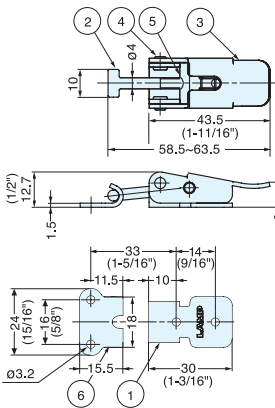

Adjust latch distance by turning arm.

- Compact size.
- Adjustable arm latch.
- Screw not included. Recommended screw size M3.
- Provides consistent hold tension for secure latching.

Item No.	Load Capacity (kg)	Weight (g)	Box (pcs)	Carton (pcs)
SCC-TF30	51 (112 lbs)	32	100	400

No.	Part Name	Material
①	Base	304 Stainless Steel
②	Latch Plate	Stainless Steel
③	Lever	304 Stainless Steel
④	Rotating Pin	303 Stainless Steel
⑤	Adjustment Shaft	
⑥	Counterplate	304 Stainless Steel

CORNER FASTENER



STF-A56AH, AC



STF-A56AH

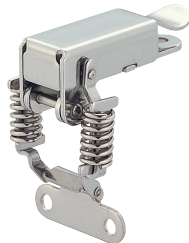

STF-A56AC

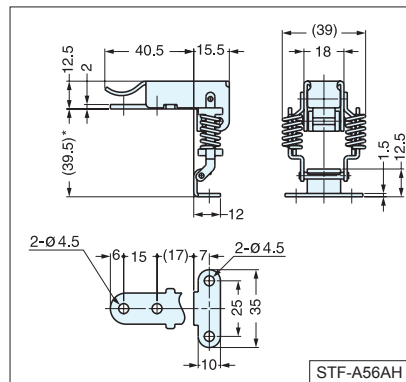

STF-A56AH

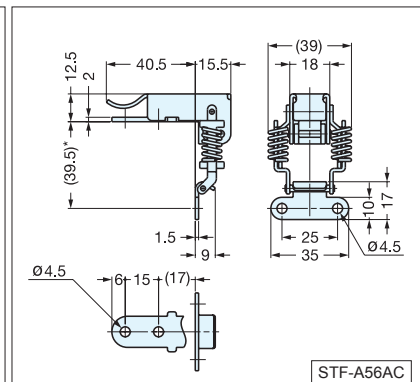

STF-A56AC

- Designed to allow front operation.
- Available in two different counterplate styles.

Material	Finish
304 Stainless Steel	Polished

Item No.	Weight (g)	Box (pcs)	Carton (pcs)
STF-A56AH	56	100	1000
STF-A56AC			

*Dimensions shown are for clamping force of "0".

*Dimensions shown are for clamping force of "0".